

ORIGINAL ARTICLE

Influences of hydrogen addition from different dual-fuel modes on engine behaviors

Sanjeevakumar Veerasangappa Khandal¹ | Ümit Ağbulut² | Asif Afzal^{3,4} |
Mohsen Sharifpur^{5,6,7} | Kaladgi Abdul Razak³ | Nima Khalilpoor⁸

¹Department of Mechanical Engineering, Sanjay Ghodawat University, Kolhapur, India

²Department of Mechanical Engineering, Faculty of Engineering, Düzce University, Düzce, Turkey

³Department of Mechanical Engineering, P. A. College of Engineering (Affiliated to Visvesvaraya Technological University, Belagavi), Mangaluru, India

⁴Department of Mechanical Engineering, School of Technology, Glocal University, Delhi-Yamunotri Marg, SH-57, Uttar Pradesh, India

⁵Department of Mechanical and Aeronautical Engineering, University of Pretoria, Pretoria, South Africa

⁶Department of Medical Research, China Medical University Hospital, China Medical University, Taichung, Taiwan

⁷Department of Mechanical Engineering, University of Science and Culture, Tehran, Iran

⁸Department of Energy Engineering, Graduate School of the Environment and Energy, Science and Research Branch, Islamic Azad University, Tehran, Iran

Correspondence

Sanjeevakumar Veerasangappa,
Department of Mechanical
Engineering, Sanjay Ghodawat
University, Kolhapur, India.
Email: khandal.sv@
sanjayghodawatuniversity.ac.in

Ümit Ağbulut, Department of
Mechanical Engineering, Faculty of
Engineering, Düzce University, 81620
Düzce, Turkey.
Email: umitagbulut@duzce.edu.tr

Asif Afzal, Department of Mechanical
Engineering, P. A. College of
Engineering (Affiliated to Visvesvaraya
Technological University, Belagavi),
Mangaluru 574153, India.
Email: asif.afzal86@gmail.com

Mohsen Sharifpur, Department
of Mechanical and Aeronautical
Engineering, University of Pretoria,
Pretoria 0002, South Africa.
Email: mohsen.sharifpur@up.ac.za

Nima Khalilpoor, Department of
Energy Engineering, Graduate School
of the Environment and Energy,

Abstract

Compression ignition (CI) engines have good performance but more exhaust emissions. Dual fuel (DF) engines have better performance and lower emissions compared to CI mode. Also, the scarcity of fossil fuels made the researchers to find alternative fuels to power CI engines. Therefore, the present work aims to use hydrogen (H₂) and honne oil biodiesel (BHO) to investigate the performance of CI engines in DF mode. Also, it aims to compare the performance of CI engines in various DF modes, namely induction, manifold injection, and port injection. First, the CI engine was fuelled completely by diesel fuel and BHO. The data were gathered when the engine ran at a constant engine speed of 1500 rpm and at 80% load. Second, the CI engine was operated in various DF modes and data were generated. CI engine operation in DF mode was smooth with biodiesel and H₂. The brake thermal efficiency (BTE) of 32% and 31.1% was reported with diesel and biodiesel, respectively, for manifold injection due to low energy content and high viscosity of biodiesel. These values were higher than CI mode and other DF modes. Fuel substitution percentage for DF manifold injection was 60% and 57% with diesel and biodiesel, respectively. Smoke, hydrocarbon (HC), and carbon monoxide (CO) emissions were lower than conventional mode, but a reverse trend was observed for oxides of nitrogen (NO_x) emissions. Heat release rate (HRR) and peak pressure (PP) were higher than conventional mode due to the fast combustion rate of hydrogen. The shortest ignition delay (ID) period was

This is an open access article under the terms of the Creative Commons Attribution License, which permits use, distribution and reproduction in any medium, provided the original work is properly cited.

© 2022 The Authors. *Energy Science & Engineering* published by Society of Chemical Industry and John Wiley & Sons Ltd.

Science and Research Branch, Islamic Azad University, Tehran, Iran.
Email: nimakhalilpoor@gmail.com

noticed for traditional diesel fuel, but it was longer for BHO biodiesel due to its higher viscosity and lower cetane number. On the contrary, the presence of hydrogen led to an increment in the combustion duration (CD) owing to the scarcity of oxygen in CD. Consequently, the paper clearly showed that the injection way of hydrogen plays a respectable role in the engine characteristics.

KEYWORDS

biodiesel of honne oil (BHO), engine performance, hydrogen, induction, manifold injection, port injection

1 | INTRODUCTION

In today's technology, the internal combustion engines have the dominant share with the rate of more than 99% in the transportation sector, and these engines have been powered by the burning of conventional fossil fuels such as diesel, gasoline, and liquefied petroleum gas.¹ However, significant exhaust pollutants arising from the burning of these fuels have contributed to environmental pollution.² Hence, most countries have revised their policies to control and mitigate the emissions for all sectors as in transportation, and some concrete steps have been taken.³ With the trigger of the environmental effects, the awareness has also been increased on the environmental issues. Fuel researchers have continuously tried to find new and environmentally friendly fuel additives.^{4,5} Due to the non-edible nature of petroleum fuels, the reserves deplete day by day, leading to volatility in the unit price of these fuels.⁶ In this framework, the importance of biofuels as renewable energy sources and fewer pollution makers is more visible. Many researchers declared that biofuels could be considered a respectable alternative fuel to conventional petroleum products thanks to their renewable, biodegradable, high-oxygen content, sulfur-free, and foreign exchange saving.⁷ Most biofuels have similar thermo-physical properties to conventional fuels. An important reduction in smoke, CO, and HC emissions is recorded when the engine fuels biofuels since incomplete combustion reduces the chemical composition of biofuels due to high-oxygen atoms. Furthermore, any modification is required on the vehicular system when the engine is fuelled by biofuels.^{5,7} However, there are some significant drawbacks in fuelling the engine with biofuels. For instance, NO_x emission generally increases when the engine runs with biofuel due to the improved combustion process.^{2,7} In addition to high NO_x, another drawback is that the engine performance worsens with biofuel usage in the cylinder. It is because biofuels have a lower energy density than of conventional petroleum products.⁷ Some attempts, such as agents, are applying for performance

improvement. Recently, with advanced technology, some solid and gas agents have been injected into the combustion chamber and biodiesel. Accordingly, many researchers decelerated that the nanoparticle addition and/or hydrogen injection presents a good opportunity to pull back the worsened engine characteristics arising from the usage of biofuel.^{2,8} The factors underlying this improvement in the engine performance are that these additives have high energy content, high catalyst effect to accelerate the chemical reactions during the combustion process, and oxidize unburnt hydrocarbon fuels, resulting in a respectable improvement in the engine characteristics.^{7,9} In particular, using hydrogen, diesel, and gasoline fuels in internal combustion engines has been a center of popular research for fuel researchers. Despite the conventional fuels and biofuels, hydrogen does not have any carbon atom in its nature. Therefore, it pulls back the CO, CO₂, smoke opacity, and HC emissions. It ensures a better option in terms of environmental aspects and contributes to reducing fuel consumption.⁸ Hydrogen in DF mode could be a better option with manifold injection for CI engine,^{10–22} but storage and safety of two fuels are a concern in today's technology. It could be overcome by producing hydrogen gas onboard using electrolysis; it also contains oxygen, a combustion promoter. This mixture, called HHO Gas or Hydroxy Gas or Brown gas, yields better combustion and emission performance.^{18,23} Hydrogen can be injected from the intake manifold to get more homogenous blends. Then, diesel fuel could be injected with multiple ignition sources toward the top dead center, resulting in complete combustion.¹⁴ Hydrogen induction-diesel DF engines yield higher BTE.^{18,19} The combustion velocities with the induction method were found at least 23% higher than that of the direct injection method.¹⁹ Hydrogen DF engine with equivalence ratio 0.4 revealed not much change in HRR as compared to diesel operation,¹⁶ and similar findings were also achieved at low load only.¹⁹ HRR recorded 21% higher for DF mode with a 7.5 lpm hydrogen flow rate than the diesel fuel mode.¹⁷ HRR with induction method was 17% higher than with injection because of higher

premixed combustion.¹⁹ The ignition delay period (ID) increased slightly with the addition of hydrogen and LPG due to reduced air intake leading to oxygen shortage in the cylinder or loss of OH radical in the reaction, thereby forming intermediate compounds.^{16,20} A higher percentage of hydrogen/LPG in the mixture showed lower ID.^{16,21} As the load increased, both pressure rise and peak pressure (PP) rates were higher due to the complete combustion of the fuel.^{16,17,24} Also, at a higher load, diesel injected was higher. Thereby, more number of ignition centers resulted in higher PP closer to TDC with higher BTE.¹⁷ At low load, hydrogen enrichment decreased PP, pressure rise, and retarded the start of combustion²⁵ because of the lack of diesel fuel required to ignite the blend. At low load, diesel injected was low, resulting in poor BTE due to rapid heat transfer to the wall.^{15,25} Smoke is reduced when the engine is fed by hydrogen and diesel fuel in comparison with that of CI mode.^{16,18,26} Most parts of diesel burn in a homogenous manner, and a high rate of hydrogen chain oxidation yields lower smoke.¹² CO emission was lower due to carbon-free fuel combustion and enhanced combustion but elevated NO_x due to an increase in gas temperature.^{11,16,18} As the hydrogen induction rate increased, nitric acid (NO) emission lowered, but NO₂ increased. NO_x level decreased with an increase in EGR percentage.¹⁴ A reduction of 14% and 19% in PP and HRR was recorded in DF mode for biodiesel according to CI mode.²⁷ At a CNG flow rate of 0.5 kg/h, HRR and PP for DF mode reduced by 4.1% and 4%, respectively, compared to biodiesel mode.²⁸ In another work, it was observed that H₂ of 8 lpm induction ensured an improvement of 5.5% for BTE, a reduction of 22%–25% for HC emissions. On the contrary, the increments of 15%, 15.6%, and 20.4% were recorded for NO_x, PP, and HRR, respectively, compared to those of DF operation.²⁹ Oxygenated fuels improved the BTE with lower exhaust energy loss.³⁰ The article reviewed the phytotoxicity and interactions of ENPs with plants at seedling and cellular levels besides providing an information gap.³¹ Jatropha biodiesel was used in blends. NO_x emissions and exhaust temperatures were identical with all blends. No significant changes in BSFC, BTE, CO₂, and gas pressures were observed.³² JBD blends (B25, B50, B75, and B100) showed lower CO, THC, smoke, and PM emissions with higher NO_x emissions. However, the engine thermal efficiency was slightly lower with higher JBD blends.³³ An increased level of oxygen concentration in fuel with biodiesel concentration effects the ignition. This causes weak development of the spray flame, increase in the natural luminosity, lower length, and width of spray flame.³⁴ Biodiesel/ethanol presents 1°CA longer ID than the others, which indicates latent heat has significant effect on ID.³⁵ The ID of blended mode is longer as compared to RCCI mode, and more sensitive to n-butanol ratio and exhaust gas recirculation (EGR) rate.³⁶

TABLE 1 Properties of various fuels used

No	Properties	Diesel fuel	BHO
1	Viscosity (cSt at 40°C)	2.5	4.5
2	Flash point (°C)	65	187
3	Calorific value (kJ/kg)	45,000	39,798
4	Density (g/L at 15°C)	830	880
5	Cetane number	45–55	44

Based on the exhaustive literature review, scarce literature research papers are available focusing on the effect of honne biodiesel (BHO) usage with H₂ induction/injection in DF mode to discuss the performance characteristics of a CI engine. To fill this gap, the present paper compares DF engines' performance, combustion and emission parts with diesel/BHO-H₂ fuel combinations at 80% load with different hydrogen supply techniques induction, manifold injection, and port injection to compare these results with CI mode results.

2 | EXPERIMENTAL PROCEDURE

2.1 | Fuels used in the current work

The present paper used diesel fuel and honne oil methyl ester as the main liquid fuels to power the engine. The emission and performance characteristics of the CRDI engine were gathered when the engine run at a constant engine speed of 1500 rpm. First, properties of diesel fuel and BHO achieved according to ASTM standards are given in Table 1, and the properties of hydrogen are given in Table 2.

2.2 | Methodology adopted

The fuel engine used for the present study to analyze the performance and emission characteristics of a diesel engine fuelled by hydrogen-enriched honne oil methyl ester and diesel fuel at different hydrogen injection scenarios is shown in Figure 1. In addition, specification of the CI engine is given in Table 3.

Table 4 provides the uncertainty analysis of measured and calculated parameters.

3 | RESULTS AND DISCUSSIONS

In the present research, the diesel engine was fed from different modes such as induction, manifold injection, and port injection, and the results achieved from these modes were compared with those of conventional mechanical

fuel injection system (CMFIS) results. The engine runs at a constant engine speed of 1500 rpm and a constant engine load condition of 80% during all experiments. CI mode, fuel IP, and IT values were equal to 21 bars and 23°BTDC, respectively, for diesel and biodiesel blends.

3.1 | BTE and BSFC in SI and MI

BTE is a very significant metric in evaluating the engine performance variations according to the modified test fuels. BTE refers to how efficiently chemical energy in the test fuels converts into mechanical work due to the combustion process in internal combustion engines. Therefore, the high BTE values are the desired output for any modified test fuel for the fuel researchers.^{29,37} Comparison of BTE and fuel substitution percentage in CI and DF modes are depicted in Figures 2 and 3, respectively, at 80% load. Considering the BTE values of neat

diesel and BHO fuels together, it is seen that the BTE for BHO fuel is lower by 5% than that of diesel fuel. It can be attributed to the calorific value of the relevant test fuels.^{38,39} As shown in Table 1, the calorific value of neat diesel fuel is higher than that of BHO fuel. Furthermore, the kinematic viscosity of BHO is much higher than that of diesel fuel. It is thought that the atomization of BHO fuel droplets worsens due to high viscosity, leading to poor combustion characteristics for biodiesel fuel.^{40–42} All these can explain less BTE with BHO test fuel than diesel fuel. Similar findings compared to neat diesel and biodiesel fuels were also presented by the previous research.^{43–45} On the contrary, BTE was found slightly higher in DF mode than CI mode. Higher flame speed and diffusivity of hydrogen could be the reason for the trend. Further DF engines with manifold injection yielded better BTE due to slightly higher H₂ fuel substitution with both diesel and biodiesel than induction and port injection. Considering Tables 1 and 2 together, it can be seen that the calorific value of H₂ gases is higher than both diesel fuel and BHO biodiesel. In other words, the energy density of the fuel increases if the hydrogen gases are present in the cylinder.

Lower BTE value for BHO fuel can be partially pulled back with the presence of hydrogen gases in the combustion chamber, which causes to improve the quality of combustion characteristics due to high flame propagation thereof. Furthermore, the burning value of hydrogen, as well as proper blending by air, also helps to improve the BTE of the engine.^{46,47} As shown in Figure 2, the BTE generally increases with the presence

TABLE 2 Properties of hydrogen

Chemical composition	H ₂
Auto-ignition temperature (K)	858
Min. ignition energy (mJ)	0.02
Flammability limits (% volume in air)	4–75
Stoichiometric air/flow ratio on mass basis	34.3
Density at 15°C and 1 bar (kg/m ³)	0.0838
Net heating value (MJ/kg)	119.93
Flame velocity (cm/s)	265–325

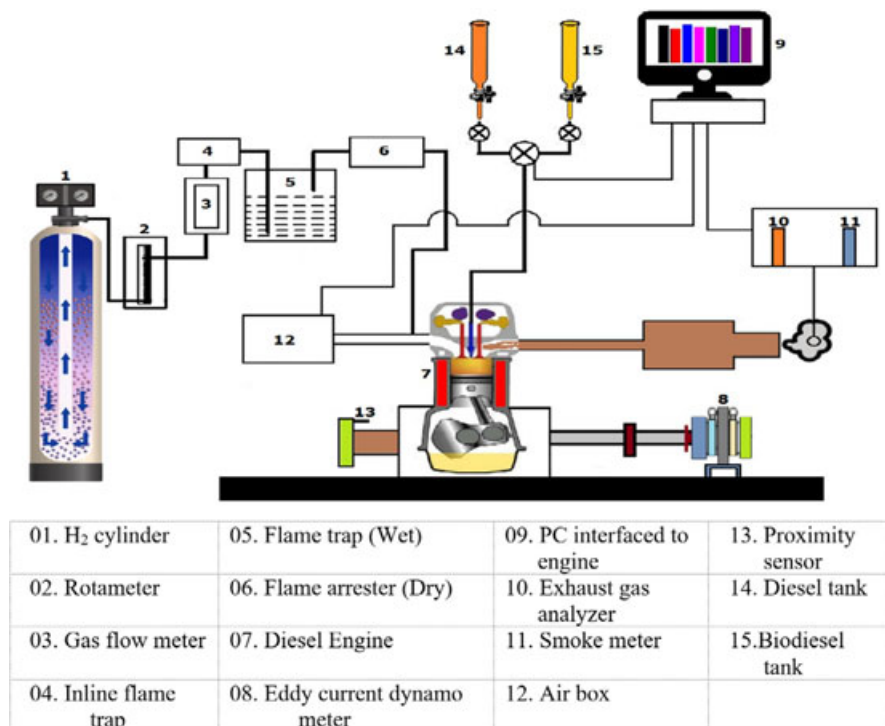

FIGURE 1 Engine setup schematic arrangement in the study

TABLE 3 Specifications of diesel engine

Sl. No.	Parameter	Specifications
1	Type	TV1 (Kirloskar make)
2	Software used	Engine soft
3	Injector opening pressure	200–225 bar
4	Governor	Mechanical centrifugal type
5	No. of cylinders	One
6	No. of strokes	Four
7	Power	5.2 kW (7 HP at 1500 rpm)
8	Bore	0.0875 m
9	Stroke length	0.11 m
10	Compression ratio	17.5
Air measurement manometer		
11	Made	MX 201
12	Type	U-Type
13	Range	100–0–100 mm
Eddy current dynamometer		
14	Model	AG - 10
15	Type	Eddy current
16	Maximum	7.5 kW at 1500–3000 rpm
17	Dynamometer arm length	180 mm
18	Fuel measuring unit- Range	0–50 ml

TABLE 4 Uncertainties analysis

Measured variable	Uncertainty (%)
HC	± 1.2
CO	± 2.5
NOx	± 5
Smoke	± 2.1
Calculated parameters	Uncertainty (%)
BTE (%)	± 1.3
HRR (J/°CA)	± 1.2

of hydrogen in the cylinder compared to neat diesel and BHO fuel in all cases.

Higher PP increased the work done that improved the BTE. As a result, maximum BTE of 32% and 31.1% was reported for diesel and biodiesel, respectively, with manifold injection, while BTE for biodiesel was reduced by 2.9% and 1.3% for induction and port injection, respectively.

Equation (1) was used to calculate the fuel substitution percentage.

$$\text{Fuel substitution percentage} = \frac{(EC_{\text{Hydrogen}})}{(EC_{\text{Hydrogen}} + EC_{\text{LF}})} (100) \quad (1)$$

where EC_{Hydrogen} – Energy contribution of H_2 fuel; EC_{LF} – Energy contribution of liquid fuel.

Fuel substitution percentage for manifold injection was 60% and 57% with diesel and biodiesel, respectively, while it decreased by 7% and 1.8% for induction and port injection, respectively, with biodiesel.

3.2 | Summary of smoke opacity, HC, CO, and NOx

Significant exhaust emissions (HC, CO, NOx emissions, and smoke opacity) in CI and DF modes are illustrated in Figures 4–7, respectively. The figures show that HC, CO emissions, and smoke opacity were fewer in DF modes according to CI mode, but the level of NOx emissions was higher. However, smoke, HC, and CO were found lower with manifold injection as compared to induction and port injection, but a reverse trend was observed for NOx emissions. The fundamental reasons for the trend recorded are the fast combustion process due to higher flame speed, higher PP, and HRR. Enhanced combustion lowered all emissions, but higher cylinder gas temperature increased NOx. Minimum CO of 0.05 volume percentage and 0.08 volume percentage were observed for diesel and biodiesel with manifold injection. CO increased by 12.5% and 25% for induction and port injection, respectively, with biodiesel. DF operation with manifold injection yielded smoke of 34 HSU and 41 HSU for diesel and biodiesel, and it increased by 7.3% and 9.8% for induction and port

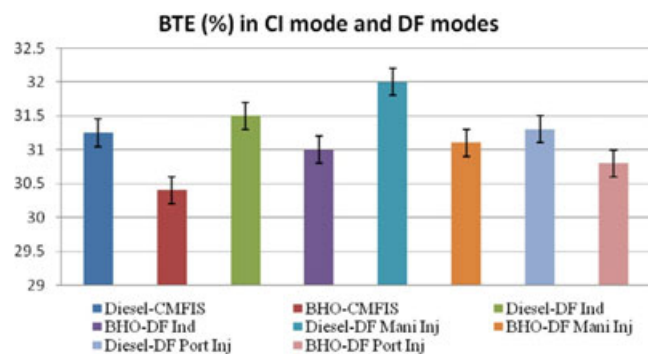

FIGURE 2 Comparison of BTE in CI mode and DF modes

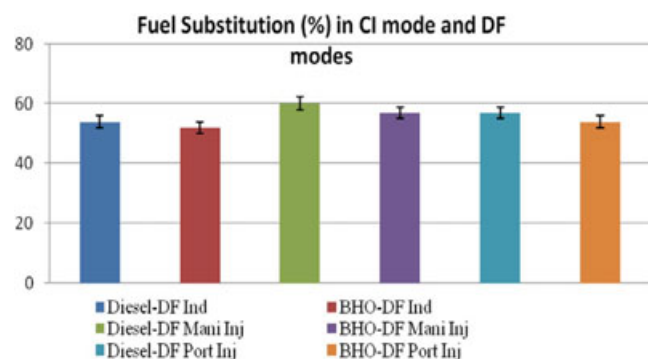

FIGURE 3 Variation of fuel substitution percentage for CI mode and DF modes

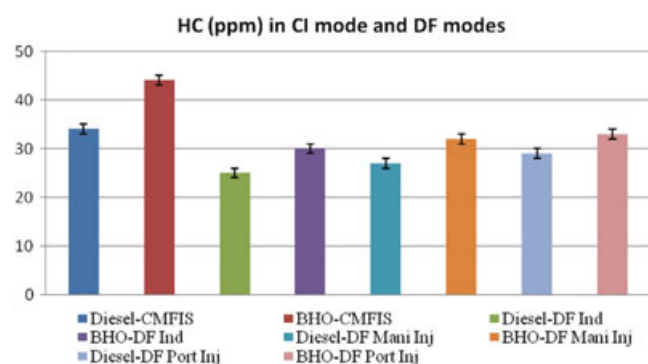

FIGURE 4 Variation of HC for CI mode and DF modes

injection, respectively, with biodiesel. NO_x was 1802 ppm and 1710 ppm for diesel and biodiesel with manifold injection, and it was reduced by 6.4% and 8.8% for induction and port injection, respectively, with biodiesel.

3.2.1 | Hydrocarbon emissions

The variation of hydrocarbon emissions is depicted in Figure 4. HC emissions are incomplete combustion products and somewhat linked to incomplete combustion

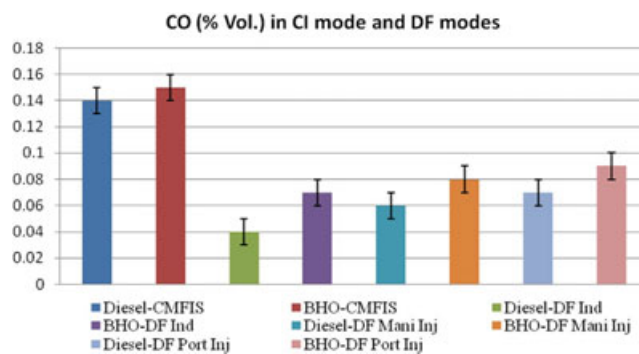

FIGURE 5 Variation of CO emissions for CI mode and DF modes

and the improper mixing of air-fuel in the combustion chamber. As the in-cylinder temperature is higher, HC emissions are more visible in the exhaust emissions. Minimum HC of 26 ppm and 30 ppm for diesel and biodiesel with manifold injection HC for biodiesel operation increased by 10% and 6.7% for induction and port injection, respectively. The HC emission for BHO test fuels is higher than that of neat diesel fuel at all strategies. It can be due to the worsened thermal efficiency and poor combustion characteristics when the engine is fuelled by BHO test fuel. On the contrary, it is noticed that HC emission gets lesser when hydrogen is present in the combustion chamber. The reason for the reduction of HC emission can be explained by the chemical structure of hydrogen being a carbon-free energy carrier. Moreover, it ensures a high burning velocity in the cylinder, the wide flammability range, and the short quenching distance arising from the hydrogen can be counted as the possible reasons leading to better burning completeness of air and fuel mixtures. In this way, it is thought that HC emissions are reducing with hydrogen in the combustion chamber.

3.2.2 | Carbon monoxide emission

Carbon monoxide (CO) emission is an exhaust product arising from incomplete combustion due to the various factors during the combustion process.⁴⁸ It represents the test fuels' lost and/or unused chemical energy. Some significant factors affecting the CO formation in diesel fuels are improper air/fuel equivalence ratio, insufficient oxygen molecules in the cylinder, fuel-rich regions, fuel types and their chemical composition, cylinder design, fuel atomization quality, injection pressure, the start of injection timing, convert it to CO₂ emissions, and operating conditions such as engine load and speed insufficient duration to oxidize CO.^{41,49,50} The variation

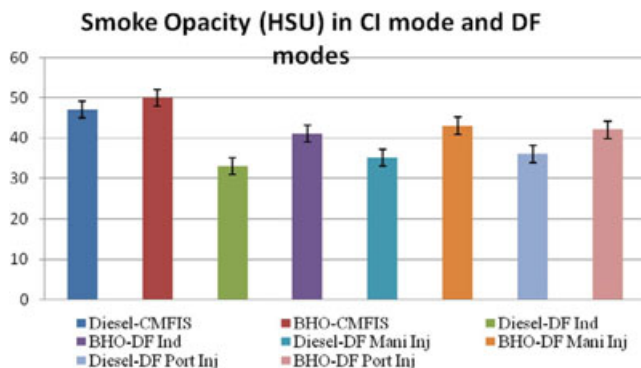

FIGURE 6 Variation of smoke opacity for CI mode and DF modes

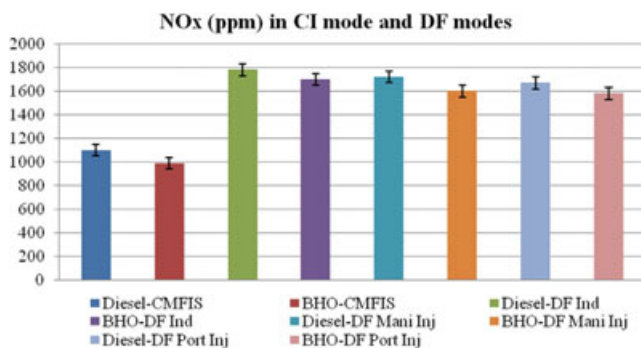

FIGURE 7 Variation of NOx emissions for CI mode and DF modes

of CO emissions is illustrated in Figure 5 with respect to varying fuel types. As can be seen from the figure, the highest CO emission is recorded when the engine is fuelled by completely BHO biodiesel. Even though biodiesel fuels have approximately 10% by weight oxygen molecules, the CO emissions slightly increased for biodiesel fuel.⁴⁰ The reason behind the slight increment in CO emission despite the oxygen molecules in the biodiesel may be related to the lower energy density of biodiesel, increased fuel consumption, and high kinematic viscosity of biodiesel. All these increased fuel consumption, leading to an increased CO emission level. Similar conclusions were also given somewhere.^{51,52} Another reason can be associated with the longer ignition delay due to the low cetane number and high kinematic viscosity of BHO biodiesel.^{53,54} These properties prolong the ignition delay period for the test fuels. In this way, the combustion duration shortens due to the long ignition delay. As a consequence of this case, BHO test fuels during the combustion process may find sufficient duration to react the oxygen atoms with carbon atoms, and/or to convert the CO emissions into CO₂ emissions due to the lacking of secondary oxidization not to find sufficiently duration. Similar points were highlighted in the previous researches.^{55–57}

3.2.3 | Smoke opacity

Smoke opacity is an incomplete combustion product just as CO and HC emissions, and it reduces with the presence of sufficient oxygen atoms in the combustion chamber. Figure 6 depicts the smoke opacity variation according to the test fuels. The variation trend of smoke opacity is like that of CO and HC emissions. BHO biodiesel increases the smoke opacity by 6% compared to conventional DF. As explained above, this phenomenon can be attributed to the low energy content, low cetane number, high viscosity, and excess oxygen content of BHO biodiesel. All of these have worsened its performance, namely more fuel consumption, and incomplete combustion products have increased at small levels. However, similar reduction trends were observed for smoke opacity with hydrogen injection, just as for HC and CO emissions.

3.2.4 | Nitrogen oxide emissions

NOx emission is one of the most significant exhaust pollutants in diesel engines, and it is strongly related to the combustion-post temperature. The reaction activity between nitrogen and oxygen atoms rises as the combustion temperature increases. As can be seen from Figure 7, the NOx emissions are within lower levels for conventional diesel and BHO biodiesel fuels. When H₂ is introduced in the combustion chamber, a significant increase is noticed for NOx emissions. The reason behind this case can be explained by a significantly higher calorific value of H₂ gases than both diesel and BHO fuels (see Tables 1 and 2). In that case, the hydrogen ensures a high-pressure rate and high in-cylinder temperature, leading to an increment in NOx emissions.^{58–60} Accordingly, NOx emission increased by 65.1% for induction mode, 55.9% for manifold injection mode, and 54.1% for port injection mode as compared to conventional diesel fuel. Similarly, it increased by 70% for induction mode, 60% for manifold injection mode, and 56% for port injection mode as compared to BHO biodiesel fuel. Similar trends were also detected in the previous papers.^{57,61} Considering the H₂ sprayed modes in terms of NOx emission, it is noticed that the modes have a very effective tool on the formation of NOx emissions, and the best results are achieved when H₂ is sprayed from port injection mode.

3.3 | PP and HRR with SI and MI

Figures 8 and 9 illustrate the comparison of PP and HRR for each CI and DF mode, respectively. Both PP and HRR

were recorded higher for DF mode than those of CI mode. Further DF engines with manifold injection showed higher PP and HRR than induction and port injection. Slightly higher H_2 fuel substitution with the fast-burning rate for diesel and biodiesel fuels is the main reason for the results recorded. Slightly higher ID and CD were observed in DF mode and provided in Figures 10 and 11, respectively. Biodiesels showed slightly lower PP and HRR due to their higher viscosity, leading to poor atomization just before the ignition, and worsen the combustion process. Another reason can be associated with the lower calorific value of biodiesel, resulting in low PP due to low energy content. With the injection of H_2 into the cylinder, PP and the heat release rate of the engine are increasing due to its high energy content. Accordingly, a maximum HRR of $93 \text{ J}/^\circ\text{CA}$ and $90 \text{ J}/^\circ\text{CA}$ was found for diesel and biodiesel with manifold injection, while HRR for biodiesel was reduced by 3.3% and 2.2% for induction and port injection, respectively. PP for manifold injection was 79 bar and 75 bar for diesel and biodiesel, respectively, while PP was reduced by 2.7% and 1.4% for induction and port injection, respectively, with biodiesel.

The ignition delay period is an important metric affecting the performance and emission characteristics of the engine. In the study, the ID period is noticed when the engine is fuelled by conventional DF. On the contrary, ID gets longer when the engine runs with BHO biodiesel. In comparison with that of DF, the ID period increased by 5.88% for BHO. The reason behind this case can be explained by the high kinematic viscosity of BHO fuel. As the viscosity increases, the diameter of fuel droplets increases. In other words, the atomization of fuel droplets worsens with high viscosity. This case retards the ignition of the relevant fuels. This is one of the reasons why the ID is longer for BHO. Another important point underlying the long ID for BHO fuel can be attributable to the cetane numbers of the test fuels. As shown in Table 1, the cetane number of BHO is lower than that of DF. In this case, the BHO requires to absorb more latent heat to evaporate. Since the fuel droplets start to ignite after the evaporation process, ID gets longer for the test fuels with a low cetane number. Accordingly, another important factor retards the ignition for BHO fuel is its low cetane number. Then with the injection of H_2 into the cylinder, the ignition delay period significantly gets longer. The reason behind it can be explained by the scarcity of oxygen and hydrogen gaseous.^{20,62,63}

As shown in Figure 11, the combustion duration (CD) is lower for DF. With BHO biodiesel in the cylinder, the CD period is highly increasing. It can be attributable to the low energy content of biodiesel. More combustion duration is required for the fuels with low energy content to reach the equivalent engine load. Another reason may be due to its long ID period due to the lower cetane number of hydrogen

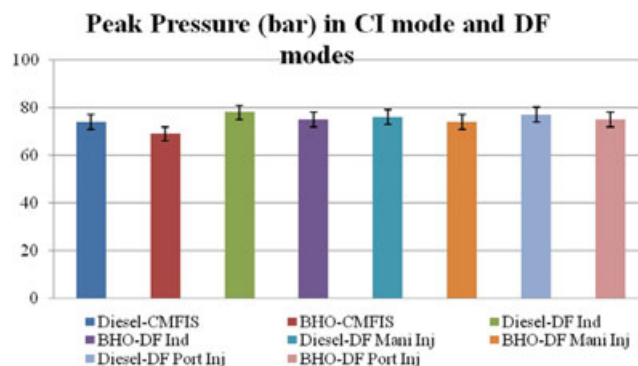

FIGURE 8 Variation of PP for CI mode and DF modes

and higher viscosity of BHO. All these properties may get longer the ID and CD for BHO biodiesel.^{64–68} Then with the injection of hydrogen gases, the CD is getting longer. It can be associated with the deteriorated air-flow ratio due to the lacking of oxygen molecules during the injection of hydrogen gases. In this case, the hydrocarbon fuels might not sufficiently oxidize, resulting in a longer combustion duration for the relevant fuels. Similar findings were also declared from the previous researchers.

4 | CONCLUSIONS

Experimental work on CI engine at 80% load in conventional mode and DF modes (Induction, manifold injection and port injection) with biodiesel/diesel and hydrogen. From this work, the following are conclusions:

- DF engine operation was smooth with biodiesel and hydrogen.
- BTE of 32% and 31.1% was reported with diesel and biodiesel, respectively, for manifold injection and is higher than conventional mode.
- Fuel substitution percentage for manifold injection was 60% and 57% with diesel and biodiesel, respectively, while it decreased by 7% and 1.8% for induction and port injection, respectively, with biodiesel.
- CO of 0.05 volume percentage and 0.08 volume percentage was observed for diesel and biodiesel with manifold injection. On the contrary, CO increased by 12.5% and 25% for induction and port injection, respectively, with biodiesel.
- DF operation with manifold injection yielded smoke of 34 HSU and 41 HSU for diesel and biodiesel, and it increased by 7.3% and 9.8% for induction and port injection, respectively, with biodiesel.
- NO_x was 1802 ppm and 1710 ppm for diesel and biodiesel with manifold injection, and it was reduced by 6.4% and 8.8% for induction and port injection, respectively, with biodiesel.

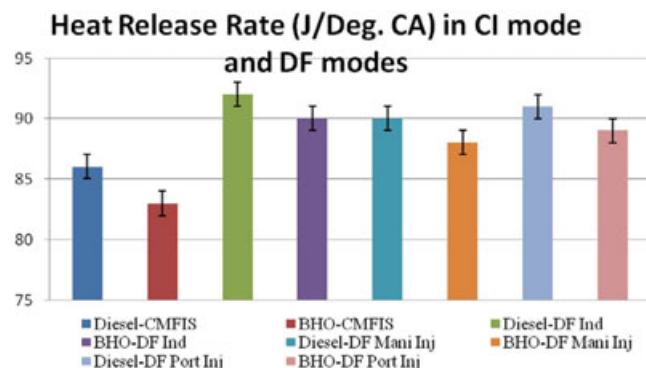

FIGURE 9 Variation of HRR for CI mode and DF modes

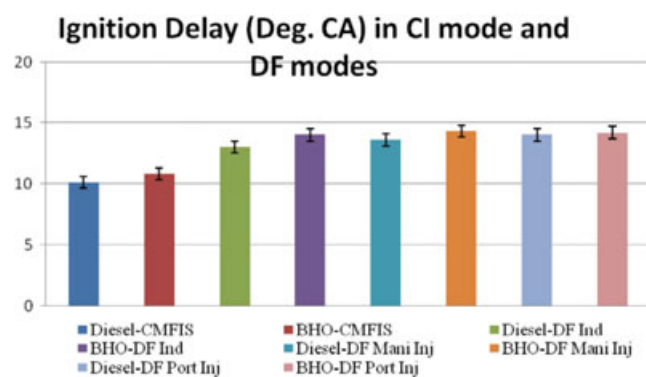

FIGURE 10 Variation of ID for CI mode and DF modes

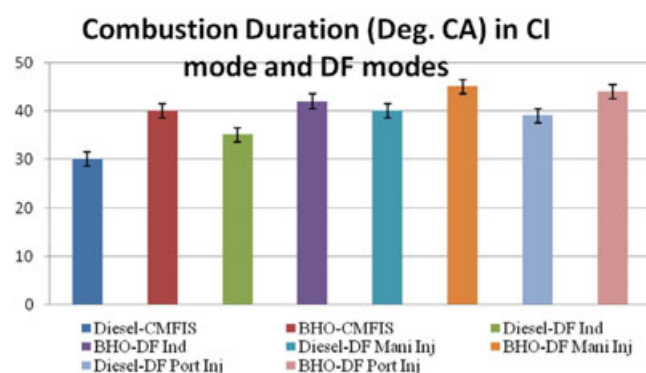

FIGURE 11 Variation of CD for CI mode and DF modes

- HRR_{max} of 93 J/°CA and 90 J/°CA recorded for diesel and biodiesel in manifold injection, while HRR for biodiesel dropped by 3.3% and 2.2% for induction and port injection, respectively.
- PP for manifold injection was 79 bar and 75 bar for diesel and biodiesel, respectively, while PP was reduced by 2.7% and 1.4% for induction and port injection, respectively, with biodiesel.

Overall, it could be concluded that the manifold injection method yielded better BTE and lower emissions with BHO and H₂ combination, thereby making CI engine operation free from fossil fuel dependence and saves the environment.

ACKNOWLEDGMENT

The authors extend their appreciation to the Sanjay Ghodawat University for giving all experimental facilities.

NOMENCLATURE

BHO	Biodiesel of honne oil
CRDI	Common rail direct injection
SI	Single injection
MI	Multiple injections
BTE	Brake thermal efficiency
H ₂	Hydrogen
NO _x	Nitrogen oxides
CO	Carbon monoxide
CI	Compression ignition
HC	Hydrocarbon
DF	Dual fuel
CR	Compression ratio
ID	Ignition delay
DME	dimethyl ether
TDC	Top dead center
BTDC	Before top dead center
HRR	Heat release rate
PP	Peak pressure
H ₂	Hydrogen
lpm	Liter per minute
BHO	biodiesel of honne oil
ID	Ignition delay
CD	Combustion duration

CONFLICT OF INTEREST

The authors declare no conflict of interest.

ORCID

Asif Afzal  <https://orcid.org/0000-0003-2961-6186>

Nima Khalilpoor  <https://orcid.org/0000-0001-9864-8152>

REFERENCES

1. Kalghatgi G, Levinsky H, Colket M. Future transportation fuels. *Prog Energy Combust Sci.* 2018;69:103-105.
2. Ağbulut Ü, Sandemir S. A general view to converting fossil fuels to cleaner energy sources by adding nanoparticles. *Int J Ambient Energy.* 2019;42(13):1569-1574.
3. Bakay MS, Ağbulut Ü. Electricity production based forecasting of greenhouse gas emissions in Turkey with deep learning, support vector machine and artificial neural network algorithms. *J Clean Prod.* 2021;285:125324.
4. Tunç N, Karagöz M, Çiftçi B, Deniz E. Environmental pollution cost analysis of a diesel engine fueled with biogas-diesel-tire pyrolytic oil blends. *Eng Sci Technol.* 2021;24(3):631-636.
5. Karagöz M. Investigation of performance and emission characteristics of an CI engine fuelled with diesel-waste tire oil-butanol blends. *Fuel.* 2020;282:118872.
6. Chong CT, Loe TY, Wong KY, et al. Biodiesel sustainability: the global impact of potential biodiesel production on the energy-water-food (EWF) nexus. *Environ Technol Innov.* 2021;22:101408.

7. Ağbulut Ü, Gürel AE, Sarıdemir S. Experimental investigation and prediction of performance and emission responses of a CI engine fuelled with different metal-oxide based nanoparticles–diesel blends using different machine learning algorithms. *Energy*. 2021;215:119076.
8. Akal D, Öztuna S, Büyükkakın MK. A review of hydrogen usage in internal combustion engines (gasoline-LPG-diesel) from combustion performance aspect. *Int J Hydrogen Energy*. 2020;45(60):35257-35268.
9. Deheri C, Acharya SK, Thatoi DN, Mohanty AP. A review on performance of biogas and hydrogen on diesel engine in dual fuel mode. *Fuel*. 2020;260:116337.
10. Köse H, Ciniviz M. An experimental investigation of effect on diesel engine performance and exhaust emissions of addition at dual fuel mode of hydrogen. *Fuel Process Technol*. 2013;114:26-34.
11. Yadav VS, Soni SL, Sharma D. Performance and emission studies of direct injection C.I. engine in dual fuel mode (hydrogen-diesel) with EGR. *Int J Hydrogen Energy*. 2012;36:3807-3817.
12. Lata DB, Misra A, Medhekar S. Effect of hydrogen and LPG addition on the efficiency and emissions of a dual fuel diesel engine. *Int J Hydrogen Energy*. 2012;37:6084-6096.
13. Mustafi NN, Raine RR. *A Study of the Emission of Dual Fuel Engine Operating with Alternative Gaseous Fuels*. SAE Paper. 2008-01-1394.
14. Singh S, Liu S, Li H. *Numerical Investigation of NO2 Formation Mechanism in H2-Diesel Dual-Fuel Engine*. SAE Paper 2012-01-0655.
15. Kenanoğlu R, Tanç B, Baltacıoğlu MK, et al. Comparison of HCNG and HHOCNG dual fuels usage with pilot injection in a non-modified diesel engine. In: *Conference Paper*, November 2015. <https://www.researchgate.net/publication>
16. Tomita E, Kawahara N, Piao Z, Fujita S. *Hydrogen Combustion and Exhaust Emissions Ignited with Diesel Oil in a Dual Fuel Engine*. SAE Paper. 2001. 2001-01-3503.
17. Saravanan N, Nagarajan G, Sanjay G, Dhanasekaran C, Kalaiselvan KM. Combustion analysis on a DI diesel engine with hydrogen in dual fuel mode. *Fuel*. 2008;87:3591-3599.
18. Bari S, Mohammad Esmail M. Effect of H₂/O₂ addition in increasing the thermal efficiency of a diesel engine. *Fuel*. 2010;89:378-383.
19. Masood M, Ishrat MM, Reddy AS. Computational combustion and emission analysis of hydrogen–diesel blends with experimental verification. *Int J Hydrogen Energy*. 2007;32:2539-2547.
20. Lata DB, Misra A. Analysis of ignition delay period of a dual fuel diesel engine with hydrogen and LPG as secondary fuels. *Int J Hydrogen Energy*. 2011;36:3746-3756.
21. Lata DB, Misra A. Theoretical and experimental investigations on the performance of dual fuel diesel engine with hydrogen and LPG as secondary fuels. *Int J Hydrogen Energy*. 2010;35:11918-11931.
22. Boretti A. Advances in hydrogen compression ignition internal combustion engines. *Int J Hydrogen Energy*. 2011;36:12601-12606.
23. Wang H-K, Cheng C-Y, Chen K-S, Lin Y-C, Chen C-B. Effect of regulated harmful matters from a heavy-duty diesel engine by H₂/O₂ addition to the combustion chamber. *Fuel*. 2012;93:524-527.
24. Shahad HAK, Abdul-Hadi N. Experimental Investigation of the effect of hydrogen manifold injection on the performance of compression ignition engines. *World Acad Sci Eng Technol Int J Mech Aerosp Ind Mechatron Manuf Eng*. 2011;5(4):763-768.
25. Santoso WB, Bakar RA, Nur A. Combustion characteristics of diesel diesel-hydrogen duel fuel engine at low load. In: *International Conference on Sustainable Energy Engineering and Application*; 2012.
26. Lata DB, Misra A, Medhekar S. Effect of hydrogen and LPG addition on the efficiency and emissions of a dual fuel diesel engine. *Int J Hydrogen Energy*. 2012;37(60):6084-6096.
27. Hiremath SS, Khandal SV, Banapurmath NR, Math VB, Gaitonde VN. Comparative analysis of performance of dual fuel (DF) and homogeneous charge compression ignition (HCCI) engines fuelled with honne oil methyl ester (HOME) and compressed natural gas (CNG). *Fuel*. 2017;196:134-143.
28. Hosmath RS, Banapurmath NR, Khandal SV, Gaitonde VN, Basavarajappa YH, Yaliwal VS. Effect of compression ratio, CNG flow rate and injection timing on the performance of dual fuel engine operated on honge oil methyl ester (HOME) and compressed natural gas (CNG). *Renewable Energy*. 2016;93:579-590.
29. Yaliwal VS, Banapurmath NR, Hosmath RS, Khandal SV, Budzianowski WM. Utilization of hydrogen in low calorific value producer gas derived from municipal solid waste and biodiesel for diesel engine power generation application. *Renewable Energy*. 2016;99:1253-1261.
30. Odibi C, Babaie M, Zare A, Nabi MN, Bodisco TA, Brown RJ. Exergy analysis of a diesel engine with waste cooking biodiesel and triacetin. *Energy Convers Manage*. 2019;198:111912.
31. Ma X, Geiser-Lee J, Deng Y, Kolmakov A. Interactions between engineered nanoparticles (ENPs) and plants: phytotoxicity, uptake and accumulation. *Sci Total Environ*. 2010;408(16):3231-3239.
32. Nurun Nabi MD, Hustad JE. Influence of oxygenates on fine particle and regulated emissions from a diesel engine. *Fuel*. 2012;93:181-188.
33. Nurun Nabi MD, Hustad JE. Influence of biodiesel addition to Fischer–Tropsch fuel on diesel engine performance and exhaust emissions. *Energy Fuels*. 2010;24(5):2868-2874.
34. Yi W, Liu H, Lei Feng YU, Wang YC, Liu W, Yao M. Multiple optical diagnostics on effects of fuel properties on spray flames under oxygen-enriched conditions. *Fuel*. 2021;291:120129.
35. Zheng Z, Xia M, Liu H, Wang X, Yao M. Experimental study on combustion and emissions of dual fuel RCCI mode fueled with biodiesel/n-butanol, biodiesel/2,5-dimethylfuran and biodiesel/ethanol. *Energy*. 2018;148:824-838.
36. Zheng Z, Xia M, Liu H, Shang R, Ma G, Yao M. Experimental study on combustion and emissions of n-butanol/biodiesel under both blended fuel mode and dual fuel RCCI mode. *Fuel*. 2018;226:240-251.
37. Ağbulut Ü, Polat F, Sarıdemir S. A comprehensive study on the influences of different types of nano-sized particles usage in diesel-bioethanol blends on combustion, performance, and environmental aspects. *Energy*. 2021;229:120548.
38. Ağbulut Ü, Karagöz M, Sarıdemir S, Öztürk A. Impact of various metal-oxide based nanoparticles and biodiesel blends on the combustion, performance, emission, vibration and noise characteristics of a CI engine. *Fuel*. 2020;270:117521.
39. Emiroğlu AO, Şen M. Combustion, performance and exhaust emission characterizations of a diesel engine operating with a ternary blend (alcohol-biodiesel-diesel fuel). *Appl Therm Eng*. 2018;133:371-380.

40. Karagöz M, Ağbulut Ü, Sarıdemir S. Waste to energy: production of waste tire pyrolysis oil and comprehensive analysis of its usability in diesel engines. *Fuel*. 2020;275:117844.
41. Ağbulut Ü, Yeşilyurt MK, Sarıdemir S. Wastes to energy: improving the poor properties of waste tire pyrolysis oil with waste cooking oil methyl ester and waste fusel alcohol—a detailed assessment on the combustion, emission, and performance characteristics of a CI engine. *Energy*. 2021;222:119942.
42. Kanth S, Debbarma S. Comparative performance analysis of diesel engine fuelled with hydrogen enriched edible and non-edible biodiesel. *Int J Hydrogen Energy*. 2021;46(17):10478-10493.
43. Sarıdemir S, Gürel AE, Ağbulut Ü, Bakan F. Investigating the role of fuel injection pressure change on performance characteristics of a DI-CI engine fuelled with methyl ester. *Fuel*. 2020;271:117634.
44. Karagöz M. ANN based prediction of engine performance and exhaust emission responses of a CI engine powered by ternary blends. *Int J Autom Sci Technol*. 2020;4(3):180-184.
45. Afzal A, Ağbulut Ü, Soudagar MEM, Razak RK, Buradi A, Saleel CA. Blends of scum oil methyl ester, alcohols, silver nanoparticles and the operating conditions affecting the diesel engine performance and emission: an optimization study using Dragon fly algorithm. *Appl Nanosci*. 2021;11(9):2415-2432.
46. Debbarma S, Misra RD, Das B. Performance of graphene-added palm biodiesel in a diesel engine. *Clean Technol Environ Policy*. 2020;22(2):523-534.
47. Yilmaz IT, Gumus M. Effects of hydrogen addition to the intake air on performance and emissions of common rail diesel engine. *Energy*. 2018;142:1104-1113.
48. İlhak Mİ, Akansu SO, Kahraman N, Ünalın S. Experimental study on an SI engine fuelled by gasoline/acetylene mixtures. *Energy*. 2018;151:707-714.
49. Patel C, Chandra K, Hwang J, et al. Comparative compression ignition engine performance, combustion, and emission characteristics, and trace metals in particulates from Waste cooking oil, Jatropha and Karanja oil derived biodiesels. *Fuel*. 2019;236:1366-1376.
50. Sayın C, Ozsezen AN, Canakci M. The influence of operating parameters on the performance and emissions of a DI diesel engine using methanol-blended-diesel fuel. *Fuel*. 2010;89(7):1407-1414.
51. Venu H, Raju VD, Lingesan S, Soudagar MEM. Influence of Al₂O₃nano additives in ternary fuel (diesel-biodiesel-ethanol) blends operated in a single cylinder diesel engine: performance, combustion and emission characteristics. *Energy*. 2021;215:119091.
52. Yilmaz N, Atmanlı A. Experimental assessment of a diesel engine fuelled with diesel-biodiesel-1-pentanol blends. *Fuel*. 2017;191:190-197.
53. Ağbulut Ü, Sarıdemir S, Albayrak S. Experimental investigation of combustion, performance and emission characteristics of a diesel engine fuelled with diesel-biodiesel-alcohol blends. *J Braz Soc Mech Sci Eng*. 2019;41(9):1-12.
54. Ağbulut Ü, Sarıdemir S, Karagöz M. Experimental investigation of fusel oil (isoamyl alcohol) and diesel blends in a CI engine. *Fuel*. 2020;267:117042.
55. Khatri N, Khatri KK. Hydrogen enrichment on diesel engine with biogas in dual fuel mode. *Int J Hydrogen Energy*. 2020;45(11):7128-7140.
56. Juknelevičius R, Rimkus A, Pukalskas S, Matijošius J. Research of performance and emission indicators of the compression-ignition engine powered by hydrogen-diesel mixtures. *Int J Hydrogen Energy*. 2019;44(20):10129-10138.
57. Nag S, Sharma P, Gupta A, Dhar A. Experimental study of engine performance and emissions for hydrogen diesel dual fuel engine with exhaust gas recirculation. *Int J Hydrogen Energy*. 2019;44(23):12163-12175.
58. Dimitriou P, Kumar M, Tsujimura T, Suzuki Y. Combustion and emission characteristics of a hydrogen-diesel dual-fuel engine. *Int J Hydrogen Energy*. 2018;43(29):13605-13617.
59. de Moraes AM, Justino MAM, Valente OS, de Moraes Hanriot S, Sodr e JR. Hydrogen impacts on performance and CO₂ emissions from a diesel power generator. *Int J Hydrogen Energy*. 2013;38(16):6857-6864.
60. Deb M, Sastry GRK, Bose PK, Banerjee R. An experimental study on combustion, performance and emission analysis of a single cylinder, 4-stroke DI-diesel engine using hydrogen in dual fuel mode of operation. *Int J Hydrogen Energy*. 2015;40(27):8586-8598.
61. Sharma P, Dhar A. Effect of hydrogen supplementation on engine performance and emissions. *Int J Hydrogen Energy*. 2018;43(15):7570-7580.
62. Kumar CB, Lata DB, Mahto D. Analysis of ignition delay by taking Di-tertiary-butyl peroxide as an additive in a dual fuel diesel engine using hydrogen as a secondary fuel. *Int J Hydrogen Energy*. 2020;45(29):14806-14820.
63. Jabbr AI, Koylu UO. Influence of operating parameters on performance and emissions for a compression-ignition engine fueled by hydrogen/diesel mixtures. *Int J Hydrogen Energy*. 2019;44(26):13964-13973.
64. Medisetty VM, Kumar R, Ahmadi MH, Vo DV, Ochoa AA, Solanki R. Overview on the current status of hydrogen energy research and development in India. *Chem Eng Technol*. 2020;43(4):613-624.
65. Ghazvini M, Sadeghzadeh M, Ahmadi MH, Moosavi S, Pourfayaz F. Geothermal energy use in hydrogen production: a review. *Int J Energy Res*. 2019;43(14):7823-7851.
66. Jalili M, Ghasempour R, Ahmadi MH, Chitsaz A, Holagh SG. Exergetic, exergo-economic, and exergo-environmental analyses of a trigeneration system driven by biomass and natural gas. *J Therm Anal Calorim*. 2021;280:1-21.
67. Beigzadeh M, Pourfayaz F, Ghazvini M, Ahmadi MH. Energy and exergy analyses of solid oxide fuel cell-gas turbine hybrid systems fed by different renewable biofuels: a comparative study. *J Clean Prod*. 2021;280(2):124383.
68. Fard HF, Khodaverdi M, Pourfayaz F, Ahmadi MH. Application of N-doped carbon nanotube-supported Pt-Ru as electrocatalyst layer in passive direct methanol fuel cell. *Int J Hydrogen Energy*. 2020;45(46):25307-25316.

How to cite this article: Khandal SV, Ağbulut Ü, Afzal A, Sharifpur M, Abdul Razak K, Khalilpoor N. Influences of hydrogen addition from different dual-fuel modes on engine behaviors. *Energy Sci Eng*. 2022;10:881–891. doi:[10.1002/ese3.1065](https://doi.org/10.1002/ese3.1065)