

# ULTRASOUND MEASUREMENT OF EXTERIOR WOOD COATING THICKNESS

Štěpán Hyšek<sup>1,\*</sup>, Kamil Trgala<sup>1</sup>, Hakan Fidan<sup>2</sup>, Miloš Pánek<sup>1</sup>, Martin Lexa<sup>1</sup>,  
Martin Böhm<sup>1</sup>, Jan Veverka<sup>3</sup>

## ABSTRACT

The present paper deals with the measurement of coat thickness on wood using an ultrasonic measurement method. Exterior wood coatings (waterborne acrylate dispersions) with coating film thickness between 80 – 115  $\mu\text{m}$  were examined. The non-destructive film thickness measurement used a Sursonic ultrasound measuring device, enabling measurement of the thickness of thin films on non-ferromagnetic and simultaneously non-conductive materials. The device also enables measurement of very thin layers of coating films, where the transit time of an ultrasound pulse through the film is shorter than the time width of the pulse. The accuracy of measurement using this measuring device was determined; destructive measurement using a light microscope was chosen as a reference measurement method. Differences in the results measured using the destructive and non-destructive methods were recorded; nevertheless, in most cases, these differences are smaller than the uncertainty of measurement using the light microscope. It can be concluded, therefore, that the results of the two compared methods match over the entire range of thickness of 80 – 115  $\mu\text{m}$ . The largest differences in the measurement readings from the destructive and non-destructive methods were identified in the range of 97 – 103  $\mu\text{m}$ .

**Keywords:** Acrylate dispersion; coat thickness, non-destructive measurement, ultrasonic.

## INTRODUCTION

Wooden products in exterior use are subject to abiotic (Feist 1990, Williams 2005, Evans 2008) and biotic (Schmidt 2006, Gaylarde *et al.* 2011) degradation, which significantly reduces not only their aesthetic (Valverde and Moya 2014) but also functional properties (Eaton and Hale 1993, Brischke *et al.* 2013). Wood can be protected from these effects in various ways (Hill 2006, Reinprecht 2016). One of the most common, particularly for exposures without ground contact (EN 335:1992), is the use of coating systems (Williams 2010, Evans *et al.* 2015). Construction joinery products (windows, doors) are most frequently treated using thick-layer glazes (Grüll *et al.* 2011). Being a heterogeneous material with a complex morphological surface structure (Montero *et al.* 2015, Görgün and Dündar 2018), wood requires a sufficient thickness of the coating film to ensure its durability (Moya *et al.* 2017, Evans *et al.* 2015). According to EN 927:2013, the minimum required thickness for exterior glazes is 80  $\mu\text{m}$ . Sufficient thickness is essential due to coating erosion by weather, which can be up to several dozen micrometres annually (Mamoňová and Reinprecht 2008). The thickness of an applied coating system can be measured in multiple ways (Masaryková *et al.* 2010, Grill *et al.* 2014, Moya *et al.* 2017).

<sup>1</sup>Department of Wood Products and Wood Constructions, Faculty of Forestry and Wood Sciences, Czech University of Life Sciences Prague. Prague. Czech Republic

<sup>2</sup>Department of Wood Chemistry and Wood Products, Duzce University, Düzce, Turkey

<sup>3</sup>Testima, spol. s r.o. Prague, Czech Republic

\*Corresponding author: hyseks@fd.czu.cz

Received: 10.07.2017 Accepted: 24.05.2018

The most accurate, but most time-consuming method is the use of microscopic analyses of cross-sections (Masaryková *et al.* 2010). The conventional method pursuant to EN ISO 2808:2007 results in destruction of the coating film; moreover, it is not sufficiently accurate when using a wedge cut, as the coating system – wood interface is difficult to discern. Other methods were also examined, using the contents of certain chemical compounds in the coating material (Grüll *et al.* 2014). A quick method, useful for practical application, is the determination of coating thickness using ultrasound, which has even been employed in several scientific papers (Moya *et al.* 2017, Hora and Belz 1998). The pitfall of the method is the unclarity as to whether it yields sufficiently accurate results when the surface of base material has heterogeneous structure.

Accurate measurement of thin layers with ultrasound applies knowledges of the mathematical analysis method, which reconstructs the signal based on a known reference echo and determines the layer thickness (Svilainis *et al.* 2017). It is even possible to discern and measure several separate layers (e.g., base paint, filler, top coat). The only requirement is to have a sufficient difference in the acoustic impedances of the different materials, so that a strong reflection of the ultrasonic pulse will be generated at the interface between these materials, thus enabling us to discern the interface (Bazulin and Bazulin 2009). The signal processing method (deconvolution of the signal received using the reference signal waveform) is based on the assumption that the signal received by the ultrasonic probe is composed of reflections from the different interfaces between layers. Each reflection is in the shape of a reference echo and is received with various amplitudes and temporal shifts. The temporal shift of these reflections specifies the thickness of the different layers with respect to the velocity of ultrasound in each material (Boßmann *et al.* 2012, Svilainis *et al.* 2017).

The objective of this paper was to determine the possibility of applying ultrasonic measurement of the thickness of a coating system for timber windows and determine its accuracy compared to analysis of cross-sections using a light microscope.

## MATERIALS AND METHOD

A comparison of optical and ultrasonic measurement methods was made on 60 samples with a coating film thickness range of 80 – 115  $\mu\text{m}$ . Norway spruce (*Picea abies*) with a density of 496  $\text{kg}/\text{m}^3$  (at an equilibrium moisture content of 12%) was used as a base material and waterborne acrylate dispersions for exterior wood coatings (acrylate basis with zinc oxide and phenyl-phosphates) was selected as coating and applied by spraying. The schematic depiction of measurement area is shown in Figure 1. For non-destructive measurement, a Sursonic Squirrel measuring device with 20 MHz probe was employed (Testima, Prague, Czech Republic). A time base is defined by sampling frequency of an analog-to-digital converter and is controlled by a crystal generator. The probe of the ultrasonic measuring device is 7 mm in diameter, and the measurement reading represents the average thickness of the coating in the measurement area. The probe was manually put on the measured surface and hydrogel as a coupling agent was used (Figure 2). Figure 2 further shows an oscilogramm of one measurement where the blue curve represents a received signal and the red one represents a calculated signal by deconvolution of the received signal using the reference signal waveform. The y-axis represents amplitude of signals as a function of time. Each sample for coating thickness measurement using the light microscope was cut out of the diameter of the area measured using the ultrasonic method. The image of the microscopic section was made using a Nikon light microscope with an optical magnification of 100 (0,16  $\mu\text{m}/\text{px}$ ). Each section was used to make 6 images, each 1 mm long, as shown in Figure 1. The NIS Element software was used to measure the coating thickness, ten times in each image at regular intervals; the overall measurement uncertainty was quantified at 6,8  $\mu\text{m}$  (calculated from measurement uncertainty due to measuring system and operator and statistical mistake). The sections for light microscopy were cut using a microtome; the section thickness was 30  $\mu\text{m}$ , and they were stained with a 1% aqueous solution of Safranin and Astra Blue stains.

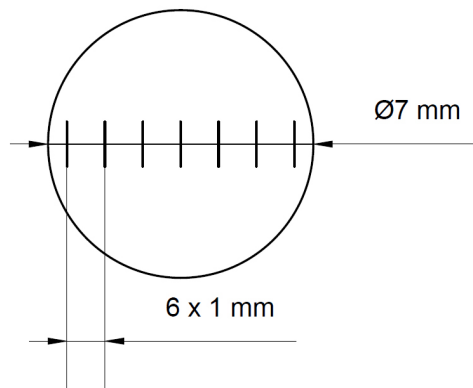

**Figure 1:** Depiction of measurement area – circle imprint of ultrasonic probe and section on the diameter for light microscope measurement.

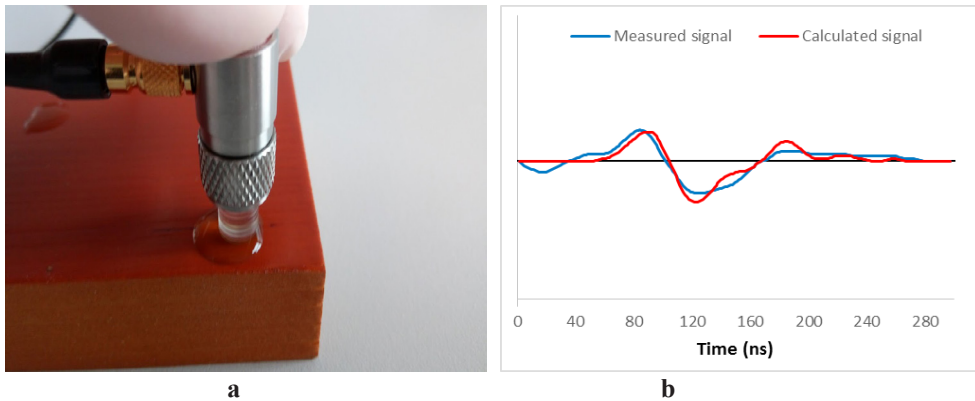

**Figure 2:** Non-destructive thickness measurement; a) ultrasonic probe on the surface, b) oscillogram of one measurement.

The coating thickness measured using the ultrasonic method  $h_u$  can be calculated knowing the sound propagation velocity in each material  $v$  based on the following Equation 1:

$$h_u = \frac{vt}{2} \quad (1)$$

where  $t$  is the measured signal transit time in the layer.

For calibration purposes, the thickness  $h_m$  measured using the light microscope is taken as the reference. The parameter  $v$  is chosen by means of calibration of the measuring device so that Equation 2:

$$\sum_{i=1}^n |h_{m_i} - h_{u_i}| \rightarrow \min \quad (2)$$

Thus Equation 3:

$$\sum_{i=1}^n \left| h_{m_i} - \frac{vt_i}{2} \right| \rightarrow \min \quad (3)$$

where, for calibration purposes,  $n = 60$ .

To quantify the difference between the layer thicknesses measured by the ultrasonic method and light microscope, the absolute difference is calculated Equation 4:

$$d_{abs} = |h_{m_i} - h_{u_i}| \quad (4)$$

as well as its relative form Equation 5:

$$d_{rel} = \frac{|h_{m_i} - h_{u_i}|}{h_{m_i}} \quad (5)$$

The producer of ultrasonic measuring device stated the measurement uncertainty as  $\pm 1\%$  from measured value. No more specific information is provided, since the thickness reading does not correspond to any signal, as is the case with normal measurement methods. The temporal position of the reflection is calculated by deconvolution of the received signal using the reference signal waveform (Crilly 1991). A slight deviation in the received signal may significantly affect the deconvolution result. The uncertainty of this measurement due to statistical data processing is quantified at  $0,5 \mu\text{m}$ . The measurement uncertainty due to device and operator inaccuracy in the measurement of samples can then be quantified based on a comparison with results obtained by the reference method, e.g., using a light microscope.

## RESULTS AND DISCUSSION

Figure 3 shows the dependency between coating thickness measured by the ultrasonic method and coating thickness measured by a light microscope. The readings of the ultrasonic method are represented by the signal transit time through the layer. According to the theoretical assumptions (Equation 1), the transit time through a layer is in direct proportion to the layer thickness and in inverse proportion to the sound propagation velocity through the material. The chart in Figure 3 shows the data interspersed by a linear regressive line without an absolute component, and the coefficient of determination for this interspersing is 0,7706. This coefficient of determination can be explained by the coarseness and structure of the wood. A coating on wood produces a diffused intermediate layer of coating absorbed in the porous wood (de Meijer *et al.* 1998, de Moura and Hernández 2006), and the reflection is not sharp and clear due to this. Its position is approximately defined by the centre of this diffused intermediate layer. Due to the different porosity of the wood at various points and degrees of surface coarseness, this intermediate layer can be of varying thickness, which may explain the greater dispersion of the readings (de Meijer *et al.* 2001). The data dispersion is also caused due to inappropriate optical identification of the interface; the overall measurement uncertainty of light microscope measurement was quantified in the methodology part at  $6,8 \mu\text{m}$ . Moreover, the results indicate that the variability in the data measured by the ultrasonic method grows with increasing coating thickness (compared based on the variance coefficient) up to the maximum value (8,6%) which is attained at the coating thickness range of  $97 - 103 \mu\text{m}$ , and then it slightly decreases. It can be hypothesed, that thickness of the coating affects its characteristics and then its velocity. Using one velocity for all the thicknesses could then explain the increasing dispersion.

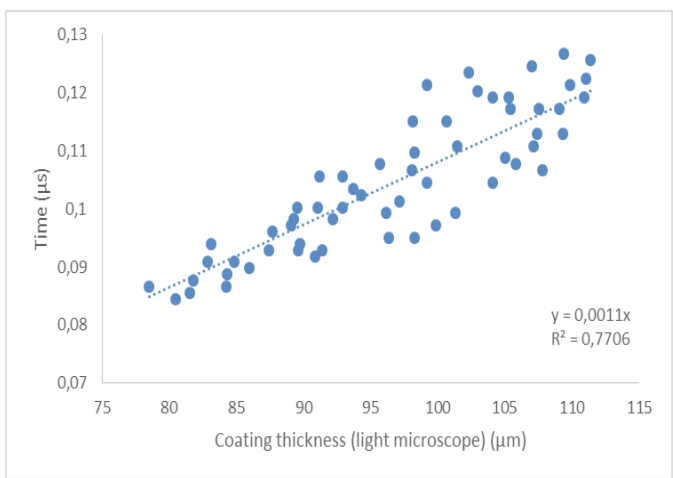

**Figure 3:** Chart of dependency between coating thickness measured by the ultrasonic method (signal transit time in the layer) and coating thickness measured by a light microscope.

Calibration was made based on the optimisation Equation (3), and the resulting sound propagation velocity in the coating was determined at  $v = 1842 \text{ m}\cdot\text{s}^{-1}$ . A comparison of the coating thickness measured by a light microscope and the ultrasonic method is shown in Figure 4; the readings are ranked in ascending order by the coating thickness determined by the light microscope. The vertical columns in Figure 4 represent the error bars; the bar length is therefore 6,8 μm for each reading obtained by the light microscope. The figure indicates clearly that the readings from the ultrasonic method oscillate around the values read by the microscope and are, in the majority of cases, within the bounds defined by the error bars.

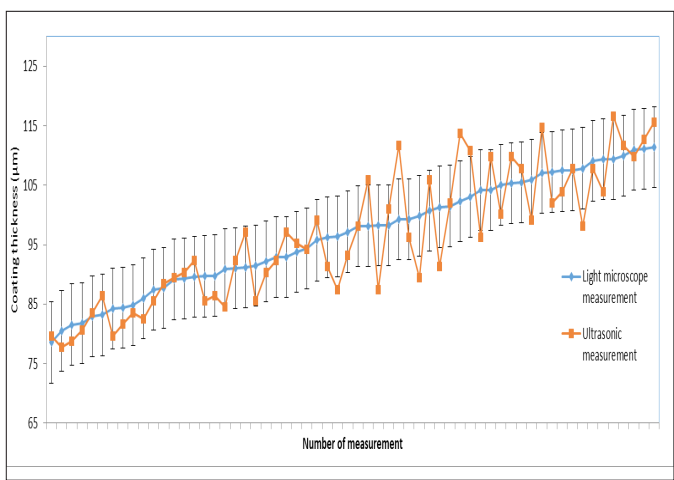
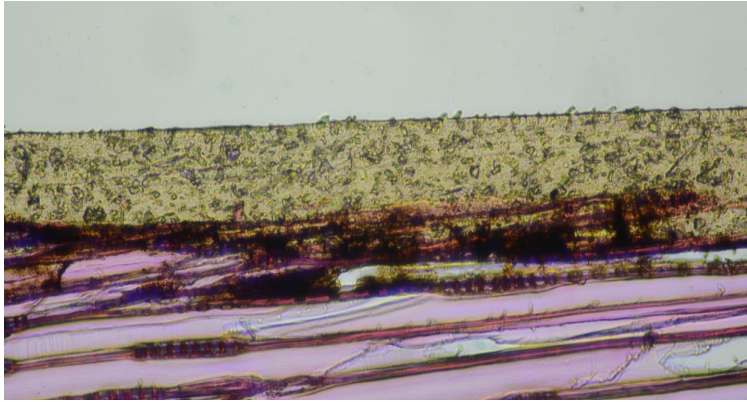

**Figure 4:** Comparison of coating thickness measured by light microscope and ultrasonic method.

The mean of the differences calculated using formulas (4) and (5) is  $\overline{d_{abs}} = 4,7\mu\text{m}$  and  $d_{rel} = 4,7\%$  respectively. This is a relatively great measurement difference between the two methods; nevertheless, these differences are lower than the uncertainty of the light microscope measurement. The standard deviation from the readings obtained by the light microscope for one measurement field (being 6x10 readings) is 4,6  $\mu\text{m}$  on average for all the measurements; the mean variance coefficient is then 4,7%. Making the value  $d_{abs}$  equal to the measurement uncertainty caused by the device or operator, we can quantify the overall uncertainty of the coating thickness measurement of the samples using the ultrasonic method as follows Equation 6:

$$u_{total} = \sqrt{u_{stat}^2 + u_{apparatus}^2} = \sqrt{0,5^2 + 4,7^2} = 4,7\mu\text{m} \quad (6)$$

As expected, the study has demonstrated slightly different measured thickness values for each sample using both experimental methods. Despite the fact that there was some inconsistency and significant differences in some results, the obtained data were mostly relevant for both measurement methods. The differences can be explained by the different measurement types and measured areas; as described in the methodology, two different measurement systems were used for the determination; while the non-destructive ultrasonic system measures an area of 154 mm<sup>2</sup> to get the average values, the cross-cutting system allows only a 7 mm straight section to be observed. The primary cause of the discrepancy might be explained as the result of failures in coating application systems or the surface roughness of the wood (de Meijer *et al.* 2001, Singh *et al.* 2007). In this case, the location of the section could affect the results depending on where it was taken; whether on the peak or valley of the roughness profile. Even though the sections which were investigated under the microscope were taken in the middle of the ultrasonic measurement areas, application failures or unevenness on the wood at unobserved and unmeasured areas could cause large differences in the average ultrasonic measurement results. Furthermore, the penetration characteristics of the coating could influence the accuracy of the measurement results (de Moura and Hernández 2006, Singh and Dawson 2004). Because wood, a heterogeneous material (Chauhan and Sethy 2016), does not have the same properties in earlywood and latewood, porosity and lumen structures make a significant difference in the penetration ability of the coating. In cases where fibers in the wood were not parallel with the surface, the coating materials leaked into the lumen gaps that became exposed. This could affect the accuracy of both methods by making determination of the wood and coating interface more difficult (de Meijer *et al.* 1998, Singh and Dawson 2006). Coating penetration into the lumen is depicted in Figure 5. Another observed mistake in the coating was air bubbles (Figure 6) which remained in the coating. In the spraying process, coating materials are spread on the wood by pressurized airflow, so air bubbles could remain in the coating layer or on the wood surface (Burns and Zhang 2001). Under a light microscope, these bubbles can be clearly seen, and in this study they were taken into account as part of the coating material. During measurement using the ultrasonic method, a bubble in the coat causes an absolute pulse reflection because the acoustic impedances of any coating and air are very different (Bazulin and Bazulin 2009, Demirli and Sanii 2001). If the bubble is small, the reflection from it is negligible compared to the signal from the whole probe surface, and the device does not recognise it. If the bubble is large enough for the device to discern the pulse reflection between the coating and the bubble, the device displays an additional layer, of a thickness equalling the distance between the coating surface and the top edge of the bubble. In both cases, if the bubble does not cover the entire measurement area of 7 mm in diameter, the device detects the reflection between the coating and the wood at the correct distance. Figure 7 shows a photograph of defect-free coating.



**Figure 5:** Coating penetration into the lumen.

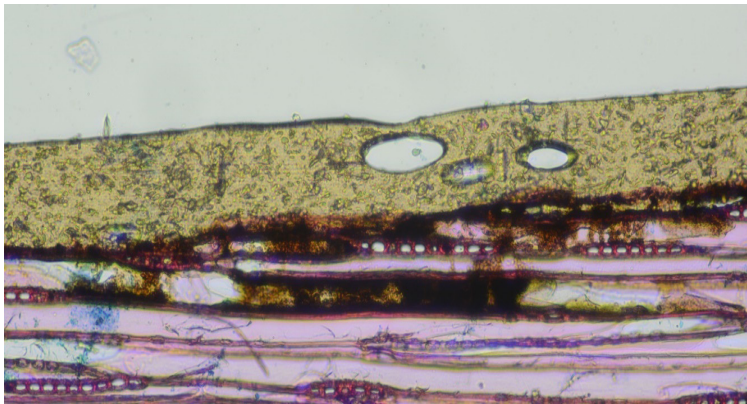

**Figure 6:** Air bubbles in the coating.

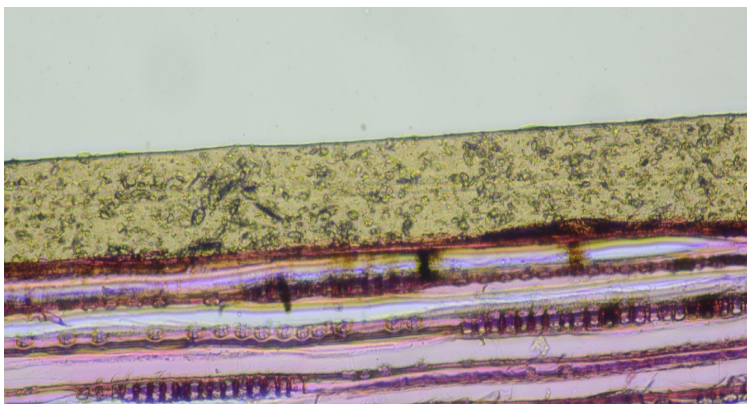

**Figure 7:** Defect-free coating.

## CONCLUSIONS

The experiments showed that measurement of coating thickness on wood using an ultrasonic measurement method achieves satisfactory results. It can be concluded, that the accuracy of non-destructive measurement of the thickness of films on non-ferromagnetic and simultaneously non-conductive materials is sufficient and that the accuracy of non-destructive measurement of the thickness of thin films on wood is comparable with destructive measurement. The results of the two compared methods match over the entire range of thickness of 80 – 115  $\mu\text{m}$ , however, the largest differences in the measurement readings from the destructive and non-destructive methods were identified in the range of 97 – 103  $\mu\text{m}$ . Sound propagation velocity in the coating (acrylate dispersion) was determined at  $v = 1842 \text{ m}\cdot\text{s}^{-1}$ .

## ACKNOWLEDGEMENTS

This work was supported by Czech University of Life Sciences Prague [grant number CIGA 20174304].

## REFERENCES

- Bazulin, A.E.; Bazulin, E.G. 2009.** Deconvolution of complex echo signals by the maximum entropy method in ultrasonic nondestructive inspection. *Acoustical Physics* 55 (6): 832.
- Boßmann, F.; Plonka, G.; Peter, T.; Nemitz, O.; Schmitte, T. 2012.** Sparse Deconvolution Methods for Ultrasonic NDT. *Journal of Nondestructive Evaluation* 31 (3): 225–244.
- Brischke, C.; Meyer, L.; Alfredsen, G.; Humar, M.; Francis, L.; Flæte, P.O.; Larsson-Brelid, P. 2013.** Natural Durability of Timber Exposed Above Ground – a Survey. *Drvna Industrija : Znanstveni Časopis Za Pitanja Drvne Tehnologije* 64 (2): 113–129.
- Burns, S.E.; Zhang, M. 2001.** Effects of system parameters on the physical characteristics of bubbles produced through air sparging. *Environmental Science & Technology* 35 (1): 204–208.
- Chauhan, S.; Sethy, A. 2016.** Differences in dynamic modulus of elasticity determined by three vibration methods and their relationship with static modulus of elasticity. *Maderas- Cienc Tecnol* 18 (2): 373-382.
- Crilly, P.B. 1991.** A quantitative evaluation of various iterative deconvolution algorithms. *IEEE Transactions on Instrumentation and Measurement* 40 (3): 558–562.
- de Moura, L.F.; Hernandez, R.E. 2006.** Evaluation of varnish coating performance for three surfacing methods on sugar maple wood. *Forest Products Journal* 56 (11/12): 130.
- Demirli, R.; Saniie, J. 2001.** Model-based estimation of ultrasonic echoes. Part II: Nondestructive evaluation applications. *IEEE Transactions on Ultrasonics, Ferroelectrics, and Frequency Control* 48 (3): 803–811.
- Eaton, R.A.; Hale, M.D.C. 1993.** *Wood: Decay, pests, and protection*. (1st ed). London: Chapman & Hall.
- EN 335. 1992.** Durability of wood and wood-based products. Definition of hazard classes of biological attack. Brussels: European Committee for Standardization.

**EN 927. 2013.** Paints and varnishes – Coating materials and coating systems for exterior wood. Brussels: European Committee for Standardization.

**EN ISO 2808. 2007.** Paints and varnishes – Determination of film thickness. Brussels: European Committee for Standardization.

**Evans, P.D. 2008.** Weathering and Photoprotection of Wood. In *Development of Commercial Wood Preservatives* (Roč. 982, s. 69–117). American Chemical Society.

**Evans, P.D.; Haase, J.G.; Seman, A.S.B.M.; Kiguchi, M. 2015.** The Search for Durable Exterior Clear Coatings for Wood. *Coatings* 5 (4): 830–864.

**Feist, W. C. 1990.** Outdoor wood weathering and protection. In *Advanced in Chemistry Series* No. 225. Washington, DC: American Chemical Society. 263–298. Chapter 11.

**Gaylarde, C.C.; Morton, L.H.G.; Loh, K.; Shirakawa, M.A. 2011.** Biodeterioration of external architectural paint films – A review. *International Biodeterioration & Biodegradation* 65 1189–1198.

**Görgün, H.V.; Dündar, T. 2018.** Strength grading of turkish black pine structural timber by visual evaluation and nondestructive testing. *Maderas-Cienc Tecnol* 20(1):56-64.

**Grüll, G.; Forsthuber, B.; Tscherne, F.; Spitaler, I. 2014.** Weathering indicator for artificial and natural weathering of wood coatings. *European Journal of Wood and Wood Products* 72 (5): 681–684.

**Grüll, G.; Truskaller, M.; Podgorski, L.; Bollmus, S.; Tscherne, F. 2011.** Maintenance procedures and definition of limit states for exterior wood coatings. *European Journal of Wood and Wood Products* 69 (3): 443–450.

**Hill, C.A.S. 2006.** *Wood modification: chemical, thermal and other processes*. Chichester, England; Hoboken, NJ: John Wiley & Sons.

**Hora, G.; Belz, A. 1998.** Measuring commercial layer-thickness on wood with an ultrasonic unit. *Paint & Coatings Industry* 14 (11): 62–66.

**Mamoňová, M.; Reinprecht, L. 2008.** Structure and color of acrylate coatings after outer and inner 1-yearlong exposition. In *Interaction of Wood with Various Forms of Energy*. Technical University in Zvolen - Slovakia 91-97.

**Masaryková, M.; Pánek, M.; Reinprecht, L. 2010.** Micro-structural analysis of coatings with nanoscale particles after ageing in Xenotest. In *Wood Structure and Properties*. Technical University in Zvolen – Slovakia 209-216.

**de Meijer, M.DE.; Thurich, K.; Militz, H. 1998.** Comparative study on penetration characteristics of modern wood coatings. *Wood Science and Technology* 32 (5): 347–365.

**de Meijer, M. DE.; Thurich, K.; Militz, H. 2001.** Quantitative measurements of capillary coating penetration in relation to wood and coating properties. *European Journal of Wood and Wood Products* 59 (1): 35–45.

**Montero, M.J.; de la Mata, J.; Esteban, M.; Hermoso, E. 2015.** Influence of moisture content on the wave velocity to estimate the mechanical properties of large cross-section pieces for structural use of Scots pine from Spain. *Maderas-Cienc Tecnol* 17 (2): 407-420.

**Moya, R.; Rodríguez-Zúñiga, A.; Vega-Baudrit, J.; Puente-Urbina, A. 2017.** Effects of adding TiO<sub>2</sub> nanoparticles to a water-based varnish for wood applied to nine tropical woods of Costa Rica

exposed to natural and accelerated weathering. *Journal of Coatings Technology and Research* 14 (1): 141–152.

**Reinprecht, L. 2016.** *Wood Deterioration, Protection and Maintenance*. John Wiley & Sons.

**Schmidt, O. 2006.** *Wood and Tree Fungi: Biology, Damage, Protection, and Use*. Springer Science & Business Media.

**Singh, A.P.; Dawson, B.S. 2004.** Confocal microscope - A valuable tool for examining wood-coating interface. *Journal of Coatings Technology and Research* 1 (3): 235–237.

**Singh, A.P.; Dawson, B.S.W. 2006.** Microscopic assessment of the effect of saw-textured *Pinus radiata* plywood surface on the distribution of a film-forming acrylic stain. *Journal of Coatings Technology and Research* 3 (3): 193.

**Singh, A.P.; Ratz, A.; Dawson, B.S. 2007.** A novel method for high-resolution imaging of coating distribution within a rough-textured plywood surface. *Journal of Coatings Technology and Research* 4 (2): 207–210.

**Svilainis, L.; Lukoseviciute, K. ; Liaukonis, D. 2017.** Reiterative deconvolution: New technique for time of flight estimation errors reduction in case of close proximity of two reflections. *Ultrasonics* 76: 154–165.

**Valverde, J.C.; Moya, R. 2014.** Correlation and modeling between color variation and quality of the surface between accelerated and natural tropical weathering in *Acacia mangium*, *Cedrela odorata* and *Tectona grandis* wood with two coating. *Color Research & Application* 39 (5): 519–529.

**Williams, S.R. 2005.** Weathering of Wood. In *Handbook of Wood Chemistry and Wood Composites*. CRC Press.

**Williams, S.R. 2010.** Finishing of Wood. In *Wood Handbook*. General Technical Report FPL-GTR-190. Madison, WI: U.S. Department of Agriculture, Forest Service, Forest Products Laboratory: 16-39. Chapter 16.

Copyright of Maderas: Ciencia y Tecnología is the property of Universidad del Bio-Bio and its content may not be copied or emailed to multiple sites or posted to a listserv without the copyright holder's express written permission. However, users may print, download, or email articles for individual use.