

THE EFFECT OF MATERIALIST TENDENCIES ON CONSUMERS' PURCHASING DECISION STYLES: SAMPLE OF DÜZCE UNIVERSITY

MATERYALİST EĞİLİMLERİN TÜKETİCİLERİN SATIN ALMA KARAR
TARZLARINA ETKİSİ: DÜZCE ÜNİVERSİTESİ ÖRNEĞİ

Abdulaziz SEZER¹ - Faruk Kerem ŞENTÜRK²

Abstract

The aim of this study is to determine the effect of the materialist tendencies of the consumers on their purchase decision styles. For this purpose, a questionnaire has been conducted with 393 students by convenience random sampling method in the Duzce University - Faculty of Business Administration, using the materialist tendency scale and the decision making styles scale. In this study, quantitative research method has been used and research data have been collected by questionnaire technique. The data have been analyzed using SPSS and Amos programs. In this study, exploratory factor analysis for the validity of the research model and confirmatory factor analysis for the validity of the measurement model was conducted and the hypotheses were tested with the structural equation model. According to the exploratory and confirmatory factor analyses, it was seen that consumers perceived materialist tendency is in one and purchasing decision styles is in seven dimensions. In the analysis of the structural equation model proposed by using the construct validity variables, it was concluded that the materialist tendency had a significant positive effect on the dimensions of fashion consciousness, brand consciousness, quality consciousness, habitual and confused by over-choice; negative effect on brand consciousness which are the sub-dimensions of purchasing decision styles.

Keywords: *Purchasing Decision Styles, Materialism, Materialist Tendency, Ethic*

Öz

Bu çalışmanın amacı, tüketicilerin materyalist eğilim düzeylerinin satın alma karar tarzlarına etkisinin incelenmesidir. Bu amaçla materyalist eğilim ölçeği ve satın alma karar tarzları ölçeği kullanılarak, Düzce Üniversitesi İşletme Fakültesi'nde kolayda örnekleme yöntemiyle 393 öğrenci ile anket yapılmıştır. Araştırmada nicel araştırma yöntemi kullanılmış ve anket tekniği ile veriler toplanmış olup, elde edilen veriler SPSS ve Amos paket programlarında analiz edilmiştir. Çalışmada araştırma modelinin geçerliliği için açılımlayıcı faktör analizi ve ölçüm modelinin geçerliliği için ise doğrulayıcı faktör analizi yapılmış ve hipotezler yapısal eşitlik modeli ile test edilmiştir. Yapılan açılımlayıcı ve doğrulayıcı faktör analizi sonuçlarına göre tüketicilerin materyalist eğilimi tek boyutta, satın alma karar tarzlarını ise 7 boyut olarak algıladıkları görülmüştür. Yapı geçerliliği sağlanan değişkenler kullanılarak önerilen yapısal eşitlik modelinin analizinde, materyalist eğilimin satın alma karar tarzlarının alt boyutlarından olan moda odaklılık, marka odaklılık, kalite odaklılık, alışkanlık ve kararsızlık boyutlarına yönelik anlamlı pozitif etkisinin; bilinçli alışveriş boyutuna ise anlamlı negatif etkisinin olduğu sonucuna varılmıştır.

Anahtar Kelimeler: *Satın Alma Karar Tarzları, Materyalizm, Materyalist Eğilim, Etik*

¹ Arş. Gör., Düzce Üniversitesi, İşletme Fakültesi, Sigortacılık ve Sosyal Güvenlik Bölümü, abdulazizsezer@duzce.edu.tr, ORCID: 0000-0001-5666-3979

² Doç.Dr., Düzce Üniversitesi İşletme Fakültesi, İşletme Bölümü, keremsenturk@duzce.edu.tr, ORCID: 0000-0002-3055-0797

Introduction

The consumption culture, which started to take shape with the product richness and diversity that emerged in the markets towards the end of the 20th century, has caused a distraction on individuals' hedonic behaviors as well as its distancing from simplicity. Due to the characteristic of functional needs that narrows differentiation in products, the fact that the companies carry out production activities based on the hedonistic requirements brings along the increase in consumption. The belief that individuals will strive to show their place in the society, their status and, most importantly, with their consumption, and their belief that they will be valued in terms of their consumption will carry humanity to a process that can be dangerous in many aspects (Bayat & Sezer, 2018). To be successful and happy in life (Şentürk et al., 2019), to get social acceptance (Akın et al., 2013), the idea of purchasing materials has been one of the common situations in recent times.

Factors that are effective in determining how and why people shop have been an up-to-date issue for many people for many years. This curious and researched situation played an important role in the development of various consumer typologies and the emergence of purchasing decision styles with the effect of materialism. In recent years, materialism has become an increasingly important topic in the consumer behavior. Materialism, as a socio-cultural concept, expresses the importance that the majority of people in society place on high material objects (Mafini & Dhurup, 2014).

Materialism, which has become a disease of our age as it drives people to buy excessively or to buy luxury consumer goods, has become one of the important facts that need to be investigated socially due to pushing individuals to excessive indulgence in material assets and excessive consumption. Also, it directs purchasing decisions significantly by forming the source of such behaviors as the materialist tendency; brand awareness, luxury, and comfort-seeking, symbolic consumption and so on (Doğan, 2010: 58). Therefore, the materialist tendency diverts individuals from ethical purchasing behaviors that involve the consideration of the general population and particularly leads to thinking individually and making purchases.

In this context, this study was conducted to investigate the relationship between consumers' materialist tendencies and purchasing behaviors, the relationship between different purchasing behavior types are also mentioned, since the purchasing behaviors of individuals are various.

1. LITERATURE

1.1. Materialist Tendency

The materialist tendency, which is a concept that emerged when the individual sees the materials they get or desire as a purpose of life, is one of the important facts that give direction and shape to the life of the individuals. Although materialism has a positive effect on individuals at the micro-level and national economies at the macro-level, it can also lead to dissatisfaction, nervousness, consumption obsession and borrowing (Otero-López et al., 2010; Roberts & Clement, 2007).

Referring to the literature, materialist personality traits are conceptualized as personal values or social values. Materialism, which has many definitions in the literature, is generally referred to as the consumption orientation towards the pursuit of happiness and is considered as a personality trait of westerners who have a high position in industrial and post-industrial life (Campbell, 1987; McCracken, 1988; McKendrick et al., 1985; Williams, 1982). Richins sees materialism as a system of personal values (Fournier & Richins, 1991; Richins &

Dawson, 1992). Richins' definition of materialist tendency expresses a mindset regarding the relative importance of acquiring and keeping objects in individuals' lives.

Inglehart (1990) expresses this tendency as a chronic focus on high-grade needs in terms of self-expression, belonging, aesthetic satisfaction and quality of life, and low-grade needs in matters such as material comfort and physical safety. Belk (1985), on the other hand, defines the materialist tendency as one's high-level commitment to the materials. Among the behavioral indicators of the materialist tendency are; love of position, hypocrisy, jealousy, similar of hypocrisy, social issues and environmental insensitivity, egocentrism, lack of self-control and self-confidence, desire for consumption and ownership (Fournier & Richins, 1991).

Materialist tendency, which is a common concept of psychology and sociology sciences today, has been tried to be explained with many theories. When the common points of these theories are taken into consideration, three elements that form the basis of the materialist tendency stand out (Odabaşı, 1999: 97; Richins & Dawson, 1992: 309). "Centralism" is about the level of importance individuals attribute to the acquisition of property and wealth. The second factor, "happiness," expresses the belief that having valuable assets makes the individual happy and that the individual will be happier if s/he has more and better things. "Success", the third of the basic elements of the materialist tendency, can be explained as the beliefs of materialists that success can be achieved with the assets they own (Ahuvia & Wong, 2002).

The fact that the materialist tendency sets the goal of achieving success and happiness in humanity and instills the idea that they can achieve these goals through the acquisition of assets, and this situation may cause ethical problems in the environment and society, has prompted many researchers to examine the buying behavior, which is the actual indicator of consumption phenomenon. In the following title, detailed information is given about this phenomenon, which is included in the literature as purchase decisions and decision styles.

1.2. Purchase Decision Styles

Humans have to be in harmony with the environment to sustain life and meet their needs. Factors such as physical characteristics, status, and psychological status make people's desires and need different. As a result of their nature, people tend towards various pleasures and desires, and their desires and needs are shaped according to their lifestyle (Merdan, 2018). The concept of buying behavior emerges in terms of satisfying the desires and needs of individuals.

In literature, the consumer purchasing decision process is generally expressed in five stages. The process, which starts with the realization of the problem, ends with the post-purchase behavior. However, each stage in this process should be handled by considering the personal, social and psychological factors that affect consumer behavior (Mucuk, 2009: 83). Individuals' purchasing behavior process stages are shown in Figure 1.

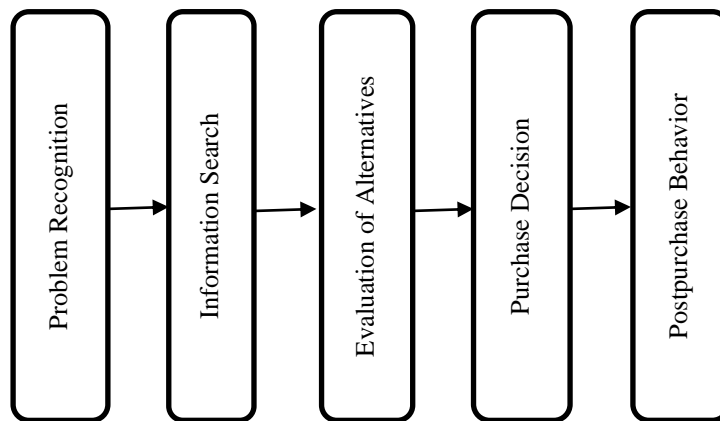

Source: Kotler & Armstrong, 2012.

Figure 1. Consumer Purchase Decision Process Stages

The factors that cause the tendency of people with different needs to meet their needs and their attitudes and behaviors while meeting these needs also differ (Merdan, 2018). Individuals' buying decisions and behaviors are shaped by certain personal and non-personal factors. Personal factors include need level, economic welfare, personality, past experiences and value priorities as examples. Non-personal factors include family life, status and roles, culture and reference groups (Oktay, 2006: 198).

Purchasing processes, which became more complex as a result of product diversity, increase in the number of stimuli and differentiation of consumer needs, created the need to define consumer orientation and caused the emergence of consumer classifications. There are many studies in the field of consumer classification (Westbrook & Black, 1985; Assael, 2004: 100; Kotler & Armstrong, 2012: 152). In the study conducted by Sproles and Kendall (1986), who conducted one of the comprehensive studies in this field, the decision-making styles of consumers were handled within the framework of eight basic features and a Consumer Styles Inventory (CSI) was developed for the measurement of these features (Dursun, Alniaçık, Kabadayı, 2013).

Table 1. Consumer Purchase Decision Styles and Features

Purchase Decision Style	Characteristics of Consumers with High Rate of Purchase Decision Style
<i>Perfectionistic, High-Quality Conscious Consumer</i>	Consumers of this style do not settle for good but do extensive research to choose the best product. They are expected to make their shopping systematically, carefully and comparatively.
<i>Brand Conscious, "Price Equals Quality" Consumer</i>	It is the way that consumers tend to buy more expensive and well-known brands. They usually prefer the best-selling and advertised brands.
<i>Novelty-Fashion Conscious Consumer</i>	A diversity of products is important for this group of consumers who are fond of innovation and fashion. They are excited about new quests and always act in the latest fashion.

<i>Recreational, Hedonistic Consumer</i>	They shop to enjoy and fun themselves.
<i>Price Conscious "Value for Money" Consumer</i>	By following the products on sale, they usually buy low-priced products. This group of consumers who make comparative shopping also wants to get the best in return for the cost they incur.
<i>Impulsive, Careless Consumer</i>	These groups of consumers, who do not make their purchases within the plan, are not concerned with how much they spend and whether their shopping decisions are accurate.
<i>Confused by Overchoice Consumer</i>	Due to the high amount of information, they are often in indecision. The high number of brands and stores makes it difficult for them to choose from.
<i>Habitual, Brand- Loyal Consumer</i>	These consumers, who have their favorite brands and stores, do not easily change their brands.

Source: Sproles & Kendall, 1986: 271-274.

When Table 1 is analyzed, it is seen that the styles from the purchase decision styles except for price-oriented are non-rational consumer buying behaviors. When the literature is examined, there are also classifications where the price-oriented style is handled in the non-rational class. The difference of this type of price orientation from the definition of Sproles and Kendall is that consumers perceive quality as price equals quality and act accordingly. In other words, it is the purchasing decision style that states that the products with high prices can move away from rationality with the idea that their quality will be high.

1.3. The Relationship between Materialist Tendency and Purchase Decision Styles

There are many studies in the literature on the relationship between materialist tendency and purchase decision styles. Although the materialist tendency is the source of many social problems, it encourages consumers to purchase and acquire assets by believing that they would be happy. On the other hand, while the materialist tendency forms the basis of modern consumer culture, it affects the type, quality and, price of the products purchased over time (Richins & Dawson, 1992: 304; Quadir, 2012). According to the literature, materialism has been associated with various consumer behaviors. Examples of these behaviors include social consumption motivation (Fitzmaurice & Comegys, 2006), coercive/compulsive consumption (Rindfleisch, Burroughs & Denton, 1997; Roberts, Manolis & Tanner, 2003), instant / unplanned purchase (Bae, 2012; Podoshen & Andrzejewski, 2012), brand orientation (Kamineni, 2005), brand loyalty (Ailawadi, Neslin & Gedenk, 2001), attitude towards advertising (Yoon, 1995), social impact and compliance behavior (Schroeder & Dugal, 1995), perceived social status (Fischer & Gainer, 1991; Fah et al., 2011), status consumption and consumer independence (Goldsmith & Clark, 2012), remarkable purchase (Podoshen et al., 2011) and self-esteem (Deci & Ryan, 1995). Although there is no direct study on the effect of the materialist tendency on the purchasing decision styles of consumers, there are many studies on the effect of the purchasing decision and the consumption tendency (Ger & Belk, 1996; Lynn & Haris, 1997; Rindfleisch, Burroughs & Denton, 1997; Watson, 2003; Troisi, Christopher & Marek, 2006).

Lee and Ahn (2016) have found that there is a positive relationship between materialist values and consumption. They concluded that materialism leads individuals towards consumption and material desires. On the other hand, they concluded that individuals with a

low level of materialistic values had high levels of control for consumption. Therefore, it can be stated that materialism is associated with passionate, thoughtless and remarkable buying behavior (Chan & Prendergast, 2007; Dittmar et al., 2007; Flouri, 1999: 709; Nguyen, 2003: 9). Considering the reverse logic, individuals with low materialistic tendencies can be interpreted to have high levels of self-control towards purchasing behavior and to avoid consumption when necessary.

In another study, Goldberg, Gorn, Peracchio & Bamossy (2003) have found that young people with high materialistic values exhibit more frequent shopping and less saving behavior, are more interested in trendy new products and convince their parents to buy more products. Besides, it has been determined that the materialist tendency is related to the status/show-off consumption, which can arise as a result of the tendency of the person, the trend towards quality and expensive brand products, expressed as his desire to show his status, financial strength and success to others (Eastman et al., 1997; Roberts, 2000; Heaney et al., 2005; Aslay, Ünal & Akbulut, 2013).

As a result of another study conducted by Quadır (2012), the adaptation of individuals to materialist values negatively affects the balance in consumption preferences throughout their lives. It has been stated that they have exceeded their budgets and spent their lives in debt and materialist values have been effective in the disappearance of traditional values such as sharing and solidarity.

In his study, Heilbroner (1956: 23) stated that wealthy and materialist individuals attribute value to their assets based on their prices rather than on the benefits and satisfaction they receive from these assets. Considering that the value of an asset is related to many factors such as its compatibility with fashion, its quality, and its brand, it can be interpreted that materialist individuals may have many factors influencing their purchase.

Ünal and Erciř (2006) concluded in their study to investigate the effects of consumers' values on their purchasing styles that the dimensions of "sense of success, enjoying life, respecting yourself and respecting others", which are the sub-dimensions of personal values and materialist tendency, have a significant effect on purchase decision styles (brand orientation, experiencing diversity, innovation and fashion orientation, habit orientation, perfectionism, shopping expertise) / conscious shopping, looking for a change, taking time to enjoy shopping, unplanned shopping). Later on, the method, findings, conclusions and suggestions of the study, with the prediction that the purchasing decision styles given above may be related to the definitions mentioned in the materialist tendency literature, are included.

2. METHOD

2.1. Purpose of the Research

The purpose of this research is to examine the effects of materialist tendency levels of consumers on purchasing decision styles.

2.2. Universe and Sampling

The universe of the research consists of 3113 students studying at the Faculty of Business Administration at Düzce University. While determining the sample of the research, considering the necessity of having a high representative power of the sample, the random sampling method is used considering the number of students in the departments of the Faculty of Business Administration (Business, Insurance and Social Security, Health Management, International Trade, Management Information Systems and International Relations). Stratified sampling is used in cases where there are substrates or subunit groups in a defined universe.

The important thing here is to work on the universe based on the existence of substrates in the universe (Yıldırım & Şimşek, 2005, p.105).

The questionnaire was applied to 393 students in total, above 346, which is the lower limit value with random sampling method in line with the calculated numbers. Random sampling is the sampling method in which the researcher tries to collect data from the easiest and most accessible subjects until s/he reaches the size of sampling s/he needs for the study (Gürbüz & Şahin, 2016, p. 134).

2.3. Data Collection Tools

A questionnaire is used as the data collection technique in this study. In this study, which was carried out to determine the effects of materialist tendency levels of consumers on purchasing decision styles, the materialist tendency scale and purchasing decision styles were used. In this section, information about the relevant scale and resources will be given. Besides, the results of exploratory and confirmatory factor analysis applied to the scales will be given. Exploratory factor analysis (EFA) is a type of analysis conducted to find factors and produce theory based on the relationships between variables (Büyüköztürk, 2002: 470-483). Confirmatory factor analysis (CFA) is a type of analysis used in cases where the purpose of examining the validity of the structure is to verify the previously determined scale factor structure (Büyüköztürk, 2016: 119).

2.3.1. Materialist Tendency Scale

In the study, materialist tendency scales (Cronbach $\alpha = .87$) which was developed by Richins and Dawson (1992) had been used. The original scale consists of 18 items, the study short form (Richins & Dawson, 2004) with 9 items (Cronbach $\alpha = .84$) was used.

2.3.2. Purchase Decision Styles Scale

In this study, the Consumer Styles Inventory (CSI), developed by Sproles and Kendall (1986), which determines the decision-making styles of consumers and developed for the measurement of these features, is used to measure the decision-making styles. Dursun, Alınçık, and Kabadayı (2013) adapted the scale to the Turkish language and the scale form in their adapted studies was used. Since the scale, which was perceived as 8 dimensions in the original, was perceived as 9 dimensions in the form adapted to Turkish consumers. Due to this difference in studies, it was deemed necessary to conduct exploratory factor analysis.

2.4. Research Model and Hypotheses

This study is conducted with the estimation model, which is one of the relational research methods. In estimation models, correlation can be calculated as well as simple regression and multiple regression methods can be used (Metin, 2014). Regression analysis refers to the explanation of the relationship between a dependent variable and the independent variable or variables thought to have an effect on this dependent variable with a model (Gürbüz & Şahin, 2016: 271). In this regard, the model developed to determine the effect of materialist tendency levels of consumers on purchasing decision styles is shown in Figure 2.

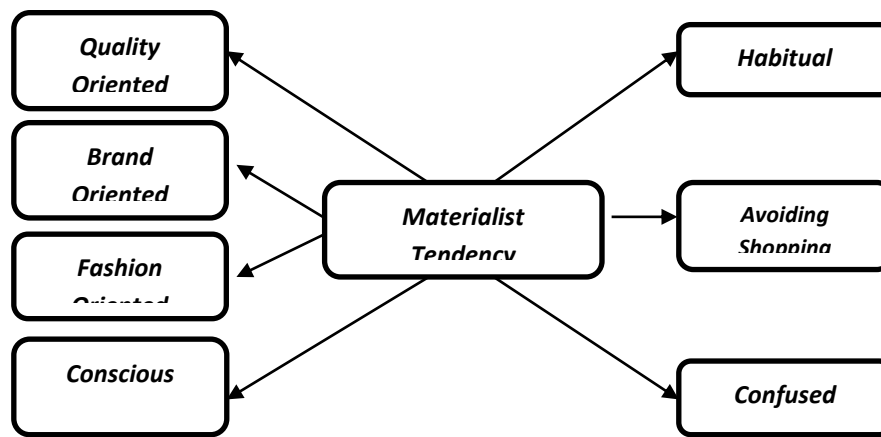

Figure 2. Research Model

The basic hypotheses developed based on this information about the studies in the related literature are as follows;

H₁: Materialist tendencies of individuals have a statistically significant effect on their purchase decision styles.

H_{1a}: The materialist tendencies of individuals have a statistically significant positive effect on quality-oriented purchasing decisions.

H_{1b}: The materialist tendencies of individuals have a statistically significant positive effect on brand-oriented purchasing decisions.

H_{1c}: The materialist tendencies of individuals have a statistically significant positive effect on fashion-oriented purchasing decisions.

H_{1d}: The materialist tendencies of individuals have a statistically significant negative effect on conscious shopping purchasing decisions.

H_{1e}: The materialist tendencies of individuals have a statistically significant positive effect on habitual purchasing decisions.

H_{1f}: The materialist tendencies of individuals have a statistically significant positive effect on confused purchasing decisions.

H_{1g}: The materialist tendencies of individuals have a statistically significant negative effect on avoiding shopping purchasing decisions.

3. FINDINGS

3.1. Findings Related to Demographic Characteristics

While determining the sample size, the sample table created by Gürbüz and Şahin (2016: 132), Bartlett, Körtlik and Higgins (2001: 47) was used and it was concluded that the size should consist of at least 346 people as shown in Table 2.

Table 2. Sample Numbers by Departments

Department	Sample
Business Administration	75
Insurance and Social Security	58
Health Management	68
International Trade	65
Management Information Systems	56
International Affairs	24
Total	346

59.5% of the participants in the study are female and 40.5% are men. Considering the monthly income of the participants, 31% had an income of 500 TL and below, and 47.8% had an income of 501-1000 TL. When the monthly average income of their families is analyzed cumulatively, it is seen that the vast majority (78%) have an income of minimum wage or more. The distribution of students' department, on the other hand, is observed to be above the minimum sample size as stated in Table 2.

3.2. Findings Related to Exploratory Factor Analysis and Reliability Analysis

As a result of the EFA for Materialist Tendency Scale, the variable that was first perceived in 2 dimensions. It was 3 times the difference between the eigenvalue of the first factor (3.691) and the eigenvalue of the second factor (1.270), and the percentage of the first factor's total variance was higher than the other factor (46%) was considered as one factor (Büyüköztürk, 2014: 147). For this reason, the scale was analyzed again with the principal components analysis technique, and a single factor structure that explains 46% of the total variance was obtained. Item 4 was removed from the scale because the factor loading was less than .40. Also, the Kaiser-Meyer-Olkin (KMO) sampling adequacy coefficient (.84) and Barlett's Test of Sphericity were found meaningful. Also, the materialist tendency scale has a high level of reliability (Cronbach Alpha = .82) according to Özdamar's (1999) criteria values.

Based on these data, it can be interpreted that the sample size is sufficient in measuring and using this variable and that the data structure is suitable for factor extraction. Data on the EFA and reliability analysis results for the relevant variable are shown in Table 3.

Table 3. Materialist Tendency EFA and Reliability Analysis Findings

Variables	Factor Loadings	Explained Variance
▪ MT6	.822	.46
▪ MT5	.780	
▪ MT8	.768	
▪ MT7	.735	
▪ MT3	.700	
▪ MT9	.521	
▪ MT2	.517	
▪ MT1	.498	

Extraction Method: Principal Component Analysis; Rotation Method: Varimax; Total Explained Variance: .46; KMO Sampling Adequacy: .84; $p=0,000<0.001$; Cronbach Alfa: .82

As a result of the EFA for Purchasing Decision Styles Scale, it was observed that the dimensions of "indecision" and "experience the confusion of information" were gathered under the same factor and the related dimensions were combined as a single factor named "confused". Since the "price-oriented" dimension and the reverse-coded version of the "shopping without mind" dimension were gathered under the same factor, these two dimensions, which have come close to each other in terms of meaning, were combined under the name of "conscious shopping". When the analysis results given in Table 4 are analyzed, it can be interpreted that the sample size is sufficient in measuring and using this variable and the data structure is suitable for factor extraction.

As a result of the reliability analysis, quality oriented is highly reliable ($\alpha = .85$), brand oriented ($\alpha = .79$), fashion oriented ($\alpha = .76$), habitual ($\alpha = .64$), confused ($\alpha = .78$) and avoiding shopping ($\alpha = .74$) are moderately reliable and conscious shopping dimension ($\alpha = .52$) is lowly reliable according to the Cronbach Alfa coefficients of Özdamar (1999).

Table 4. Purchasing Decision Styles EFA and Reliability Analysis Findings

	Factor Loadings	Explained Variance
Quality-Oriented		
▪ PDS3	.858	.14
▪ PDS2	.839	
▪ PDS1	.795	
▪ PDS4	.736	
Brand-Oriented		
▪ PDS6	.850	.12
▪ PDS7	.822	
▪ PDS8	.643	
▪ PDS5	.643	
Confused		
▪ PDS18	.820	.11
▪ PDS17	.777	
▪ PDS21	.750	

▪ PDS22	.691	
Conscious Shopping		
▪ PDS12	.743	
▪ PDS13	.632	.08
▪ PDS11	.623	
▪ PDS14	.514	
Avoiding Shopping		
▪ PDS20	.871	.08
▪ PDS19	.846	
Fashion-Oriented		
▪ PDS10	.795	.07
▪ PDS9	.746	
Habitual		
▪ PDS15	.759	.07
▪ PDS16	.640	
Extraction Method: Principal Component Analysis; Rotation Method: Varimax; Total Explained Variance: .67; KMO Sampling Adequacy: .77; p=0,000<0.001		

3.3. Findings Related to Confirmatory Factor Analysis

CFA was performed for Materialist Tendency Scale to verify the structure revealed in EFA. The fit indices of the CFA results are given in Table 5; model diagram and factor coefficients are given in Figure 3.

768

Table 5. Materialist Tendency CFA Findings

Fit Indices	Acceptable Values ²	Perfect Values ¹	Actual Values
χ^2/df	$2 \leq \chi^2/df \leq 5$	$0 \leq \chi^2/df \leq 2$	3.298
GFI	$.80 \leq GFI \leq .95$	$.95 \leq GFI \leq 1.00$.963
CFI	$.80 \leq CFI \leq .95$	$.95 \leq CFI \leq 1.00$.962
TLI	$.80 \leq TLI \leq .95$	$.95 \leq TLI \leq 1.00$.941
NFI	$.80 \leq NFI \leq .95$	$.95 \leq NFI \leq 1.00$.947
RMSEA	$.05 \leq RMSEA \leq .10$	$.00 \leq RMSEA \leq .05$.077

¹(χ^2/df , RMSEA* Schermelleh-Engel, Moosbrugger & Müller, 2003: 52; NFI, GFI, CFI, TLI* Hooper, Coughlan & Mullen, 2008: 58), ²(χ^2/df , GFI, TLI* Simon et al., 2010: 239; RMSEA* Marsh, 2012: 785; CFI* Kline, 2011: 208; NFI* Hooper et al., 2008: 55).

Considering Table 5, it is seen that GFI, CFI, TLI, and NFI values are in the perfect fit range and χ^2 / df and RMSEA values are in the acceptable value range. Therefore, the validity of the materialist tendency scale obtained by EFA was confirmed by CFA. The diagram of the model obtained by CFA is given in Figure 3.

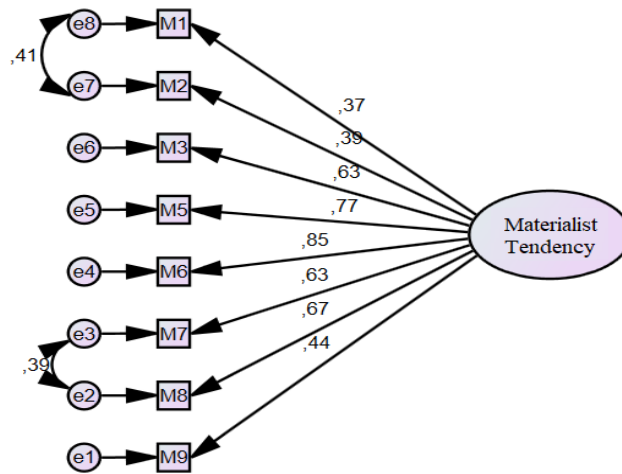

Figure 3. Materialist Tendency CFA Model Diagram

CFA for Purchase Decision Styles Scale was performed to verify the structure revealed in EFA. Fit indices of CFA results are given in Table 6; the model diagram is given in Figure 4.

Table 6. CFA Findings for Purchase Decision Styles

Fit Indices	Acceptable Values ²	Perfect Values ¹	Actual Values
χ^2/df	$2 \leq \chi^2/df \leq 5$	$0 \leq \chi^2/df \leq 2$	1.965
GFI	$.80 \leq GFI \leq .95$	$.95 \leq GFI \leq 1.00$.922
CFI	$.80 \leq CFI \leq .95$	$.95 \leq CFI \leq 1.00$.936
TLI	$.80 \leq TLI \leq .95$	$.95 \leq TLI \leq 1.00$.920
NFI	$.80 \leq NFI \leq .95$	$.95 \leq NFI \leq 1.00$.880
RMSEA	$.05 \leq RMSEA \leq .10$	$.00 \leq RMSEA \leq .05$.050

¹(χ^2/df , RMSEA* Schermelleh-Engel,Moosbrugger&Muller, 2003: 52; NFI, GFI, CFI, TLI* Hooper, Coughlan&Mullen, 2008: 58),²(χ^2/df , GFI, TLI* Simonet al., 2010: 239; RMSEA* Marsh, 2012: 785; CFI* Kline, 2011: 208; NFI* Hooper et al., 2008: 55).

When Table 6 is examined, it is seen that the GFI, CFI, TLI, χ^2 / df and RMSEA values of the fit values are in the perfect fit range and the NFI value is within the acceptable value range. Therefore, the validity of the scale of purchasing decision styles obtained by EFA was confirmed by CFA. The diagram of the model obtained by CFA is given in Figure 4.

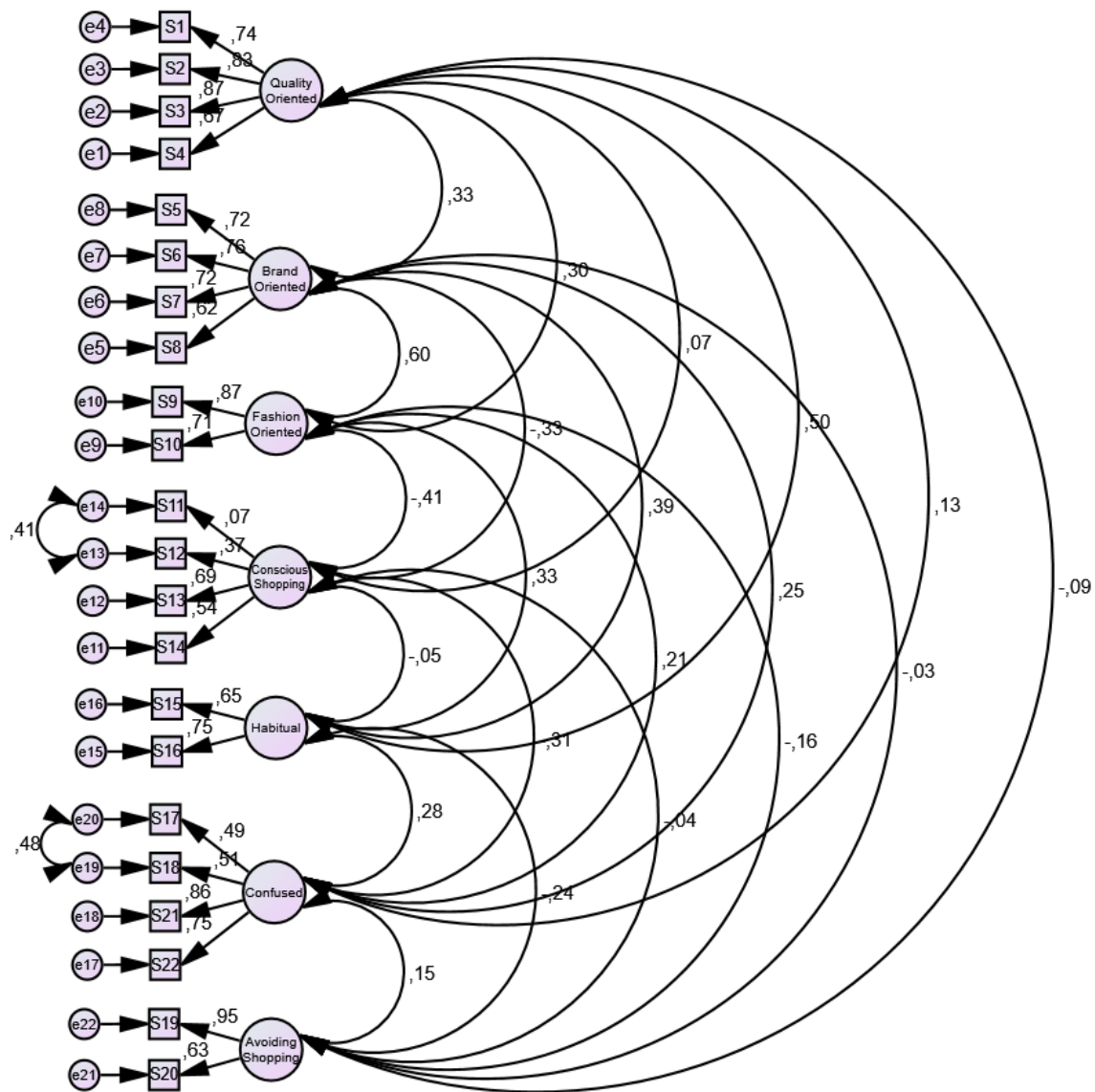

Figure 4. Purchase Decision Styles CFA Model Diagram

3.4. Findings Related to Structural Equation Model

As a result of the reliability and factor analysis, it was seen that the scales can be used in the analyses to be conducted for the study and the stage of testing the hypotheses developed within the framework of the proposed structural equation model has been analyzed. At this stage, research hypotheses were tested with the structural equation model. First of all, to get healthy results from the structural equation model, the goodness of fit values of the proposed model should be in the range of acceptable goodness of fit values. Information on acceptable value ranges in the literature regarding acceptable and perfect fit values and information about fit values that emerged in the research model are shown in Table 7.

Table 7. The Goodness of Fit Values for the Structural Equation Model

Fit Indices	Acceptable Values ²	Perfect Values ¹	Actual Values
χ^2/df	$2 \leq \chi^2/df \leq 5$	$0 \leq \chi^2/df \leq 2$	2.245
GFI	$.80 \leq GFI \leq .95$	$.95 \leq GFI \leq 1.00$.864
CFI	$.80 \leq CFI \leq .95$	$.95 \leq CFI \leq 1.00$.878
TLI	$.80 \leq TLI \leq .95$	$.95 \leq TLI \leq 1.00$.865
NFI	$.80 \leq NFI \leq .95$	$.95 \leq NFI \leq 1.00$.801
RMSEA	$.05 \leq RMSEA \leq .10$	$.00 \leq RMSEA \leq .05$.056

¹(χ^2/df , RMSEA* Schermelleh-Engel, Moosbrugger & Müller, 2003: 52; NFI, GFI, CFI, TLI* Hooper, Coughlan & Mullen, 2008: 58), ²(χ^2/df , GFI, TLI* Simonet et al., 2010: 239; RMSEA* Marsh, 2012: 785; CFI* Kline, 2011: 208; NFI* Hooper et al., 2008: 55).

When the analysis results of the proposed structural equation model shown in Table 7 are analyzed, χ^2 / df value, which is among the goodness of fit values, was realized as 2.245 and it was found to be within the acceptable value range. It is determined that GFI value .864, CFI value .878, TLI value .865, NFI value .801 and RMSEA value is .056 and they are in the acceptable value range. The parameter estimates of the structural model providing the goodness of fit values are shown in Table 8.

Table 8. Standardized Regression Coefficients and Parameter Estimates for the Model

Endogenous Variable	Exogenous Variable	Std. Reg. Coefficient	Std. Error	p-Value
Conscious Shopping ←	Materialist Tendency	-.163	.099	.034*
Avoiding Shopping ←	Materialist Tendency	-.063	.151	.672
Fashion-Oriented ←	Materialist Tendency	.501	.202	***
Brand-Oriented ←	Materialist Tendency	.433	.123	***
Quality-Oriented ←	Materialist Tendency	.316	.093	***
Habitual ←	Materialist Tendency	.351	.114	***
Confused ←	Materialist Tendency	.227	.117	***

*** significant at the % 0,1errorlevel

* significant at the % 5errorlevel.

When Table 8 is analyzed, materialist tendency has significant ($p < .001$) and positive effects on the fashion-oriented, brand-oriented, quality-oriented, habitual and confused dimensions (.501; .433; .316; .351; .227 respectively), which are the sub-dimensions of the buying decision styles. It is seen that also materialist tendency has a significant ($p < .05$) and a negative effect on conscious shopping (-.163). Besides this materialist tendency does not have a significant ($p > .05$) effect on avoiding shopping dimension. In other words, while H_{1a} , H_{1b} , H_{1c} , H_{1d} , H_{1e} , and H_{1f} hypotheses are accepted, H_{1g} hypothesis is rejected. The path analysis of the proposed structural equation model is given in Figure 5.

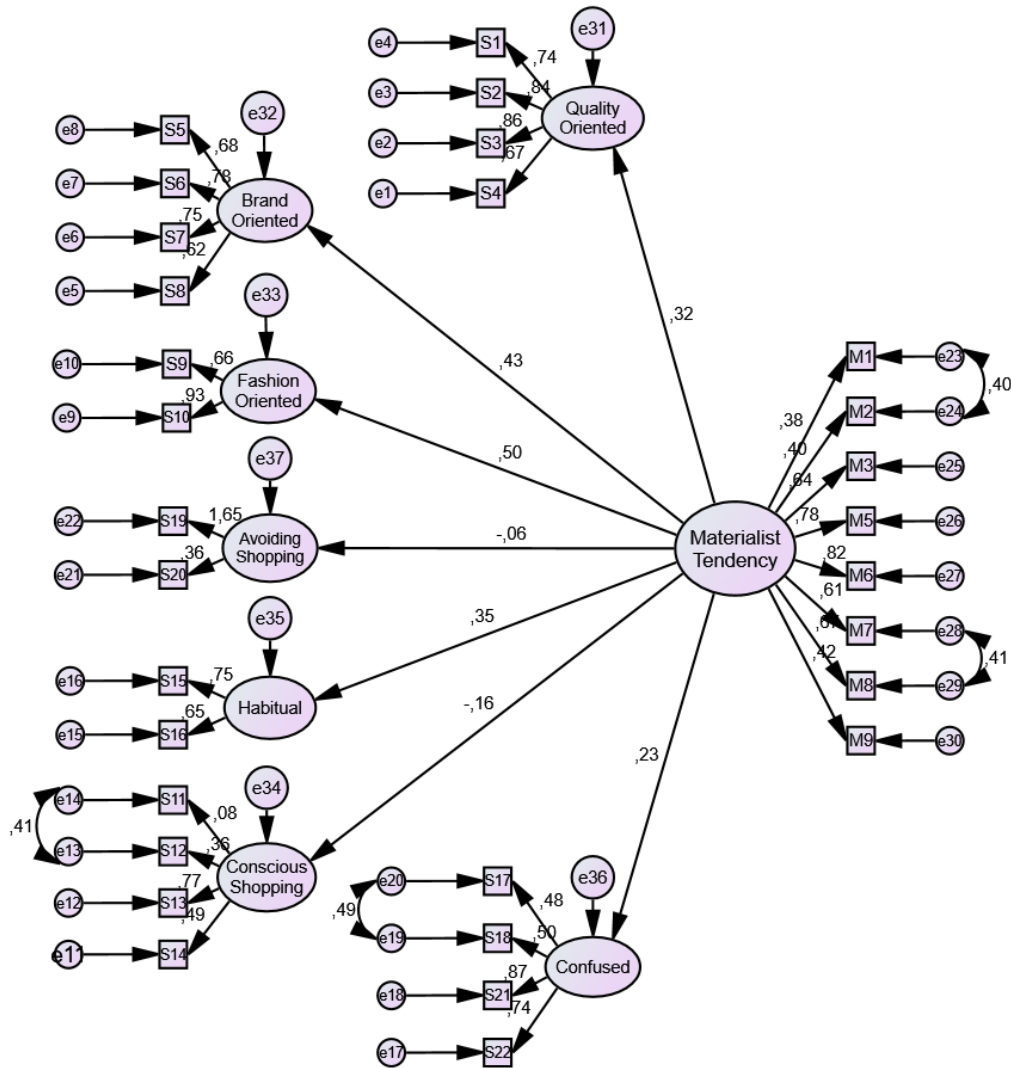

Figure 5. Proposed Structural Equation Model Path Analysis Diagram

4. CONCLUSION AND RECOMMENDATIONS

The materialist tendencies of individuals negatively affect the budget balances that they constantly try to keep at a certain level to sustain their lives, making their unavoidable needs feel imperative and moving away from their conscious purchasing behaviors and consequently to their negative moods such as unhappiness, dissatisfaction, and ambition; sharing also paves the way for many humane values such as altruism and sacrifice. Because of these grave consequences, the idea that happiness and success can be achieved by putting material in the center of life has become an important subject to be investigated.

There are various definitions of the concept of materialist tendency that produce the aforementioned results. These definitions include individuals place possession of material assets at the center of their lives; they unite in the idea of linking satisfaction and dissatisfaction, success or failure, being happy or unhappiness to the multiplicity of this asset acquisition in terms of quantity and quality. Purchasing behaviors, personality traits, interactions with their environment, values, status and so on that consumers tend to target with the stated asset acquisition target are affected by many factors and it occurs in various ways with the effect of these factors. In literature, various forms of behaviors have been introduced and this variety has been conceptualized as purchasing behavior styles. When looking at the common point of these styles, it can be said that there are two different

purchasing styles which are conscious and unconscious purchasing behavior styles. These two styles are divided into branches and explained.

With this study, it has been investigated whether these tendencies of consumers with materialist tendencies have an impact on purchasing decisions and if so, which type of purchasing decision style. There are many studies on what the effects of the materialist tendencies are. Many of these studies seem to be related to the effects of materialist tendency on consumption. However, the dimensions of purchasing decision styles include those that have an anti-consumption basis such as conscious shopping and avoiding shopping. Considering that the materialist tendency observed as a common result as a result of many studies in the literature, encourages individuals to purchase behavior with the thought of assuring unconsciously, status, success, and happiness, it turns out to be negatively related to the conscious buying decision style. With this study, the intentions of individuals with materialist tendencies to make a purchase decision were investigated empirically and the distinction was made possible to be clarified.

As a result of the EFA and CFA for the scales, consumers perceive the dimensions of the materialist tendency as "centralism", "success" and "happiness" as one dimension, unlike the original scale. It was observed that they perceive 9 consumer purchasing styles (fashion orientation, brand orientation, quality orientation, price orientation, habit, avoiding shopping, experiencing information confusion, shopping without thinking and indecision) in 7 dimensions, unlike the original scale.

The structural equation model has been established with variables that have structural validity and the model has been analyzed. According to the results of the analysis, the significant and positive effects of the materialist tendencies of the consumers on the fashion-oriented, brand-oriented, quality-oriented, habitual and confused purchasing behaviors, which are the sub-dimensions of the purchasing decision styles, while materialist tendency has a significant and negative effect on conscious shopping purchasing behavior. It has been observed that it does not affect on the avoiding shopping dimension which is another dimension of purchase decision styles. Although there are no similar studies on this subject in the literature, related topics have been widely studied. It has emerged as a result of many studies that materialism is identified with passion, thoughtless and remarkable purchasing behavior (Chan & Prendergast, 2007; Dittmar et al., 2007; Flouri, 1999: 709; Nguyen, 2003: 9). Goldberg, Gorn, Peracchio & Bamossy (2003), on the other hand, have added fashion-oriented to these behavior styles and concluded that individuals with high materialist tendencies display fashion and show-oriented buying behavior. Heilbroner (1956: 23), on the other hand, observed in his study that wealthy and materialist individuals attribute value to their assets rather than to the benefits and satisfaction they receive. Looking at today's pricing policies, it is seen that the value of a product is shaped and perceived according to factors such as the brand, quality, compatibility of fashion, and the place where it is presented. Therefore, it can be suggested that individuals with materialistic tendencies will behave in purchasing behavior due to such factors. In this study, the results were presented and supported in line with the studies stated.

at The examination of the results of the analysis in terms of meaning, reveals that materialism causes individuals to acquire assets, the indulgence of wealth and unconscious purchasing. Considering the literature, status consumption, symbolic consumption, compulsive purchase, hedonic consumption, instant purchase and so on, it can be stated that the common points of the concepts are the unconscious consumption behavior that results from negative feelings and thoughts such as unhappiness, dissatisfaction, and regret. On the other hand, the negative effect of the materialist tendency emerging as a result of the study on

the “conscious shopping” dimension, which is the sub-dimension of purchasing decision styles, supports this interpretation.

While materialism puts happiness and success as the main goal of the facts mentioned before humanity, it says that achieving this goal can be achieved through the adoption of the essential notion of centralism. In other words, while materialist individuals determine their life goals as being happy and successful, they believe that they can achieve this goal through indulgence in material and acquisition of assets and they try to live a life in this direction. However, it has been revealed as a result of many studies that consumption and asset acquisition harm life satisfaction. Therefore, it is seen that the three dimensions of materialism contradict each other. With this study, it has been determined that the materialist tendency leads individuals to purchase styles that will lead them to unhappiness and dissatisfaction afterward.

While consumers who make purchasing decisions under the influence of marketing activities, on the one hand, should stay away from activities that contradict their marketing ethics and responsibilities, on the other hand, there is a need to act within the framework of ethical and social responsibility regarding purchasing actions and results (Torlak, 2007: 317). 21st-century technology and resources are sufficient to meet the needs of all humanity and to survive. But some of the 19th-century economists, especially Thomas Malthus, said that “the human population has increased geometrically, and the nutrients have decreased arithmetically. For this reason, he came up with the idea that the human population should be limited in order not to be left behind. However, while the increase in population does not affect restricting resources, approximately 4.5 billion tons of food is produced annually for the world population of about 8 billion (Climate-Related Transboundary, 2008), this production amount is enough to feed 10 billion people. Therefore, it can be interpreted that these ideas of the so-called intellectuals of Malthus and his period were revealed and defended as a manifestation of the materialist mindset. According to the report published by the United Nations (UN) Food and Agriculture Organization (FAO) on October 16, World Food Day (Climate-Related Transboundary, 2008), 805 million people worldwide are hungry and every 4 seconds a human dies because of hunger. In other words, one out of every 9 people on earth cannot be fed enough. In another study titled “Options for keeping the food system within environmental limits” under the leadership of the University of Oxford and published in the international, prestigious science journal *Nature* for global food and climate change (Springmann et al., 2018), it is possible to create a sustainable food system that will feed 10 billion people in 2050. However, to achieve this, it is stated that besides vegetable-based nutrition, the need to reduce food wastes by at least 50 percent. Therefore, in the light of the information given, this production surplus, which could prevent the hunger and deaths mentioned to the society as a materialist, especially for those people who are faced with death due to starvation and failing to meet some of their essential needs, it is believed that the individuals who tend to become more aware of their “excessive consumption” will be more decisive and effective.

In the process of developing marketing strategies, marketing professionals will be able to take advantage of what kind of purchasing behaviors consumers take with the influence of materialist tendency, to hold companies in the market and gain competitive advantage. In this context, considering the effects of the materialist tendency, marketers and salespeople have a focus on brand, fashion, quality (price = quality idea), habit, unconsciously shopping and confusion, and their customer performance of sales personnel positively affects their sales performance (Kethüda, 2018). As a requirement of customer-oriented sales style, it will ensure customer loyalty in the long term by providing necessary guidance to help customers evaluate their own needs. Besides, due to the ethical projects for a sustainable environment,

which are included in the social responsibility areas of businesses (Şentürk et al., 2019), the fact that companies that adopt the social marketing approach include messages regarding avoiding the purchasing behavior styles stated in the advertising content as a requirement of conscious consumption will possibly make a positive contribution.

The individuals' attempts to explain their places in society, their status, and the values they have with their consumption since childhood appears as an important subject to be investigated. It will be beneficial for both educational scientists and social scientists to work to control the use of the individuals' assets, successes and social status as a means of self-expression. Thus, the problematic behaviors can be addressed and instead, individuals who have acquired the habit of purchasing goods and services not to belong to a certain group but to meet their needs can be encouraged and supported.

Therefore, in future studies, it can be examined whether the income level has an intermediary role in the effect of materialist tendency on purchasing decision styles and significant contributions can be made to the literature. Also, the effects of consumer behavior in different consumption groups can be broadly revealed by conducting researches on consumer groups with different regions and different family structures related to the subject. In this way, it can be compared both in terms of the consumption habits of families and can set an example for future studies on the subject.

Those who want to study on the subject in the future may develop a research model in which the factors that cause the materialist tendencies of individuals are also included and what else the materialist tendency may influence on.

REFERENCES

- Ahuvia, A. C., and Wong, N. (2002). Personality and values based materialism: their relationship and origins. *Journal of Consumer Psychology*, 12 (4), 389–402.
- Ailawadi, K. L., Neslin, S. A., & Gedenk, K. (2001). Pursuing the value-conscious consumer: Store brands versus national brand promotions. *Journal of Marketing*, 65(1), 71–89.
- Akın, A., Gülşen, M., Kara, S., & Yıldız, B. (2013). Çocuklar İçin Maddi Değerler Ölçeği Türkçe Formunun Geçerlik ve Güvenirliği. *Bartın Üniversitesi Eğitim Fakültesi Dergisi*, 2(2), 68–79.
- Aslay, F., Ünal, S., & Akbulut, Ö. (2013). Materyalizmin Statü Tüketimi Üzerindeki Etkisini Belirlemeye Yönelik Bir Araştırma. *Atatürk Üniversitesi İktisadi ve İdari Bilimler Dergisi*, 27(2), 43-62.
- Assael, H. (2004). *Consumer Behavior A Strategic Approach*. Houghton Mifflin Harcourt Company, New York.
- Bae, S. Y. (2012). *Understanding ethical consumers: Assessing the moderating effects of price sensitivity, materialism, impulse buying tendency, and clothing involvement*. Colorado State University.
- Bartlett, J. E., Kotrlık, J. W., & Higgins, C. C. (2001). Organizational Research: Determining Appropriate Sample Size in Survey Research. *Information Technology, Learning, and Performance Journal*, 19 (1), 43-50.
- Bayat, M. ve Sezer, A. (2018). Bireylerin Gönüllü Sade Yaşam Tarzları ve Yaşam Doyumlarının, Geleneksellik Değeri Açısından Değerlendirilmesi: Düzce Üniversitesi Örneği. *İş Ahlakı Dergisi*, 11 (1), 69–87.

- Belk, R. W. (1985). Materialism: Trait Aspects Of Living İn The Material World. *Journal of Consumer Research*, 12, 265–280.
- Büyüköztürk, Ş. (2002). Faktör Analizi: Temel Kavramlar ve Ölçek Geliştirmede Kullanımı. *Kuram ve Uygulamada Eğitim Yönetimi Dergisi*, 32, 470-483.
- Büyüköztürk, Ş. (2014). Veri Analizi El Kitabı. Ankara: Pegem A Yayınları.
- Büyüköztürk, Ş., Çakmak, E., Akgün, Ö., Karadeniz, Ş. & Demirel, F. (2016). Bilimsel Araştırma Yöntemleri. Ankara: Pegem A Yayınları.
- Campbell, C. (1987). *The Consumer Ethic and the Spirit of Modern Hedonism*. Basil Blackwell, London.
- Chan, K. and Prendergast, G. (2007). Materialism and Social Comparison Among Adolescents. *Social Behavior and Personality*, 35 (2), 213-228.
- Climate Related Transboundary Pests and Diseases. (2008, 16 Ekim). Erişim adresi <http://www.fao.org/3/a-ai785e.pdf>
- Deci, E. L., and Ryan, R. M. (1995). Human autonomy: The basis for the self-esteem. In M. Kernis (Ed.), *Efficacy, agency, and self-esteem*, New York: Plenum Publishing Co. 31–49.
- Dittmar, H., Long, K. & Bond, R. (2007). When A Beter Self is Only a Buton Click Away: Associations Between Materialistic Values, Emotional and Identity-Related Buying Motives, and Compulsive Buying Tendency Online. *Journal of Social and Clinical Psychology*, 26 (3), 334-361.
- Doğan, S. Y. (2010). Materyalist Eğilimlerin Demografik Özelliklere Göre Farklılaşmasına Yönelik Bir Araştırma. *Cumhuriyet Üniversitesi İktisadi ve İdari Bilimler Fakültesi Dergisi*, 11(1), 57-70.
- Dursun, İ., Alnıaçık, Ü., & Kabadayı, E. T. (2013). Tüketici Karar Verme Tarzları Ölçeği: Yapısı ve Boyutları. *Uluslararası Yönetim İktisat ve İşletme Dergisi*, 9 (19), 293-304.
- Eastman, K. J., Fredenberger, B., Campbell, D., & Calvert, S. (1997). The Relationship Between Status Consumption and Materialism: A CrossCultural Comparison of Chinese, Mexican and American Students. *Journal of Marketing Theory and Practice*, 52-66.
- Fah, B. C. Y., Foon, Y. S., & Osman, S. (2011). An exploratory study of the relationships between advertising appeals, spending tendency, perceived social status and materialism on perfume purchasing behavior. *International Journal of Business & Social Science*, 2(10), 202–208.
- Fischer, E., and Gainer, B. (1991). I shop therefore I am: The role of shopping in the social construction of women's identities. In G. A. Costa (Ed.), *Gender and consumer behavior*. Salt Laje City: University of Utah Press, 350–357.
- Fitzmaurice, J. and Comegys, C. (2006). Materialism and social consumption. *The Journal of Marketing Theory & Practice*, 14(4), 287–299.
- Flouri, E. (1999). An integrated model of consumer materialism: can economic socialization and maternal values predict materialistic attitudes in adolescents? *Journal of Socio-Economics*, 28 (6), 707-724.
- Fournier, S. and Richins, M. L. (1991). Some theoretical and popular notions concerning materialism. *Journal of Social Behavior and Personality*, 6(6), 403-14.

- Ger, G., and Belk, R. W. (1996). Cross-cultural Differences in Materialism. *Journal of Economic Psychology*, 17, 55–77.
- Goldberg, M. E., Gorn, G. J., Peracchio, L. A. & Bamossy, G. (2003). Understanding Materialism Among Youth. *Journal of Consumer Psychology*, 13 (3), 278–288.
- Goldsmith, R. E., and Clark, R. A. (2012). Materialism, Status Consumption, and Consumer Independence. *The Journal of Social Psychology*, 152(1), 43–60.
- Gürbüz, S., ve Şahin, F. (2016). Sosyal Bilimlerde Araştırma Yöntemleri -Felsefe-Yöntem-Analiz. Gözden geçirilmiş ve genişletilmiş 3. Baskı, Ankara: Seçkin Yayıncılık.
- Heaney, J. G., Goldsmith, R. E., & Jusoh, W. J. W. (2005). Status Consumption Among Malaysia Consumers: Exploring Its Relationships with Materialism and Attention-to-Social-Comparison-Information. *Journal of International Consumer Marketing*, 17(4), 83-98.
- Heilbroner, R. (1956). *The Questfor Wealth*. New York.
- Hooper, D., Coughlan, J., & Mullen, M. (2008). Structural Equation Modelling: Guidelines for Determining Model Fit. *Electronic Journal of Business Research*, 6(1), 53–60.
- Inglehart, R. (1990). *Culture Shift in Advanced Industrial Society*. Princeton, NJ: Princeton University Press.
- Kamineni, R. (2005). Influence of materialism, gender and nationality on consumer brand perceptions. *Journal of Targeting, Measurement & Analysis for Marketing*, 14(1), 25–32.
- Kethüda, Ö. (2018). Perakende Mağazalarında Satış Temsilcilerinin Performansını Etkileyen Faktörler. *Ekonomik ve Sosyal Araştırmalar Dergisi*, 14(2), 201-217.
- Kline, R. B. (2011). *Principles and practice of structural equation modeling*. New York, NY: The Guilford Press.
- Kotler, P. and Armstrong, G. (2012). *Principles of Marketing*. 14th Edition, Pearson Education Limited, Essex, England.
- Lee, M. S. W. and Ahn, C. S. Y. (2016). Anti-Consumption, Materialism, and Consumer Well-Being. *The Journal of Consumer Affairs*, 50(1), 18–47.
- Lynn, M. and Haris, J. (1997). The Desire for Unique Consumer Products: A New Individual Differences Scale. *PsychMarke*, 14, 601-616.
- Mafini, C. and Dhurup, M. (2014). Assessing Consumer Purchasing Decision Styles: An Empirical Investigation From South Africa. *International Business & Economics Research Journal*, 13(4), 679-688.
- Marsh, H. W. (2012). Application of confirmatory factor analysis and structural equation modeling in sport and exercise psychology. In G. Tenenbaum & R. C. Eklund (Eds.), *Handbook of sport psychology*, New Jersey, NJ: John Wiley & Sons. 737–799.
- McCracken, G. D. (1988). *Culture and Consumption*. Indiana University Press, Bloomington.
- McKendrick, N., Brewer, J., & Plumb, J. H. (Eds.). (1985). *The Birth of a Consumer Society: The Commercialization of Eighteenth Century England*. Europa Publications, London.

- Merdan, K. (2018). Tüketim Kültürü Ekseninde Dini Değerler Ve Dindarlık Olgusunun Tüketicilerin Satınalma Tercihleri Üzerindeki Etkisini Ölçmeye Yönelik Bir Uygulama (Gümüşhane Örneği). *Akademik Sosyal Araştırmalar Dergisi*, 66, 196-213.
- Metin, M. (2014). Kuramdan Uygulamaya Eğitimde Bilimsel Araştırma Yöntemleri. Ankara: Pegem Akademi Yayıncılık.
- Mucuk, İ. (2009). Pazarlama İlkeleri. Geliştirilmiş 17.Basım, Türkmen Kitapevi: İstanbul.
- Nguyen, L. T. (2003). Growing up in a material world: an investigation of the development of materialism in children and adolescents. A Dissertation Submitted to the Faculty of the Graduate School of the University of Minnesota, Doctor of Philosophy.
- Odabaşı, Y. (1999). Tüketim Kültürü: Yetinen toplumun Tüketen Topluma Dönüşümü. Sistem Yayıncılık, İstanbul.
- Oktaç, K. (2006). Kırgızistan'daki Tüketicilerin Giyim Tercihleri Üzerine Bir Araştırma. *Manas Üniversitesi Sosyal Bilimler Dergisi*, 15, 197-211.
- Otero-López, J. M., Pol, E. V., Bolaño, C. C., & Mariño, M. J. S. (2010). Materialism Life Satisfaction and Addictive Buying: Examining The Causal Relationships. *Personality and Individual Differences*, 50, 772-776.
- Özdamar, K. (1999). Paket Programlar İle İstatistiksel Veri Analizi 1. Kaan Kitabevi, Eskişehir.
- Podoshen, J. S., Li, L., and Zhang, J. (2011). Materialism and conspicuous consumption in China: A cross-cultural examination. *International Journal of Consumer Studies*, 35(1), 17–25.
- Podoshen, J. S., and Andrzejewski, S. A. (2012). An examination of the relationships between materialism, conspicuous consumption, impulse buying, and brand loyalty. *The Journal of Marketing Theory & Practice*, 20(3), 319–334.
- Quadır, S. E. (2012). Materyalist Değer Eğiliminin Gelişiminde Tüketici Sosyalizasyonunun Rolü. *Eğitim ve İnsani Bilimler Dergisi*, 3(6), 31-50.
- Richins, M. L. and Dawson, S. (1992). A consumer values orientation for materialism and its measurement: scale development and validation. *Journal of Consumer Research*, 19(3), 303-316.
- Richins, M. L. and Dawson, S. (2004). The Material Values Scale: Measurement Properties and Development of a Short Form. *Journal of Consumer Research*, 31(1), 209-219.
- Rindfleisch, A., Burroughs, J. E., & Denton, F. (1997). Family structure, materialism, and compulsive consumption. *Journal of Consumer Research*, 23, 312–325.
- Roberts, J. (2000). Consuming in a Consumer Culture: College Students, Materialism, Status Consumption and Compulsive Buying. *Marketing Management Journal*, 76-91.
- Roberts, J. A., Manolis, C., & Tanner, J. F. (2003). Family structure, materialism, and compulsive buying: A re-inquiry and extension. *Journal of the Academy of Marketing Science*, 31(3), 300–311.
- Roberts, J. A., and Clement, A. (2007). Materialism and Satisfaction with Over-all Quality of Life and Eight Life Domains. *Social Indicators Research*, 79–92.
- Schermelleh-Engel K., Moosbrugger H., & Müller, H. (2003). Evaluating the fit of structural equation models: Tests of significance and descriptive goodness-of-fit measures. *MPR-Online*, 8, 23–74.

- Schroeder, J. E., and Dugal, S. S. (1995). Psychological correlates of the materialism construct. *Journal of Social Behavior & Personality*, 10, 243–253.
- Simon D., Kriston L., Loh A., Spies C., Scheibler F., Wills C., & Harter M. (2010). Confirmatory factor analysis and recommendations for improvement of the Autonomy-Preference-Index (API). *Health Expectations*, 13, 234–243.
- Springmann M, Wiebe K, Mason-D’Croz D. et al. (2018). Health and nutritional aspects of sustainable diet strategies and their association with environmental impacts: a global modelling analysis with country-level detail. *Lancet Planet Health*, 451–61.
- Sproles, G. B., and Kendall, E. (1986). A Methodology for Profiling Consumers' Decision-Making Styles. *The Journal of Consumer Affairs*, 20(2), 267-279.
- Şentürk, K. F. (2019). Etik Liderlik ve Materyalist Eğilimlerin Otel Çalışanlarının Kurumsal Sosyal Sorumluluk Algısına Etkisi: Alanya Örneği. *Seyahat ve Otel İşletmeciliği Dergisi*, 16(1), 136-153.
- Tiltay, M. A., ve Torlak, Ö. (2011). Materyalist Eğilim, Dinî Değerler, Marka Bağlılığı ve Tüketici Ahlakı Arasındaki İlişkiler. *İş Ahlakı Dergisi*, 4(7), 93-130.
- Torlak, Ö. (2007). Pazarlama ahlakı (4. Baskı). İstanbul: Beta Yayınları.
- Troisi, J. D., Christopher, A. N., & Marek, P. (2006). Materialism and money spending disposition as predictors of economic and personality variables. *North American Journal of Psychology*, 8 (3), 421–436.
- Ünal, S. ve Erciş, A. (2006). Tüketicilerin Kişisel Değerlerinin Satın Alma Tarzları Üzerindeki Etkisi. *Ticaret ve Turizm Eğitim Fakültesi Dergisi*, 1, 23-48.
- Watson, J. J. (2003). The relationship of materialism to spending tendencies, saving, and debt. *Journal of Economic Psychology*, 24, 723–739.
- Westbrook, R.A. and Black, W.C. (1985). A motivation-based shopper typology. *Journal of Retailing*, 61, 78-103.
- Williams, R. (1982). *Dream Worlds: Mass Consumption in Late Nineteenth-century France*. University of California Press, Berkeley, CA.
- Yıldırım, A. ve Şimşek, H. (2005). *Sosyal Bilimlerde Nitel Araştırma Yöntemleri*. Ankara: Seçkin Yayıncılık.
- Yoon, K. (1995). Comparison of Beliefs About Advertising, Attitude Toward Advertising, and Materialism Held by African Americans and Caucasians. *Psychological Reports*, 77(2), 455–466.