



## ANFIS and statistical based approach to prediction the peak pressure load of concrete pipes including glass fiber

Mehmet Emiroğlu<sup>a</sup>, Ahmet Beycioğlu<sup>b,\*</sup>, Servet Yildiz<sup>c</sup>

<sup>a</sup> Düzce University, Technical Education Faculty, Department of Construction Education, Konuralp, Düzce, Turkey

<sup>b</sup> Düzce University, Kaynaşlı Vocational School, Kaynaşlı, Düzce, Turkey

<sup>c</sup> Firat University, Technical Education Faculty, Department of Construction Education, Elazığ, Turkey

### ARTICLE INFO

#### Keywords:

Concrete pipe  
Peak pressure load  
Glass fiber  
ANFIS  
Multiple Linear Regression

### ABSTRACT

In this paper, Adaptive Neural Fuzzy Inference System (ANFIS) and Multiple Linear Regression (MLR) models are discussed to determine peak pressure load measurements of the 0, 0.2, 0.4 and 0.6% glass fibers (by weight) reinforced concrete pipes having 200, 300, 400, 500 and 600 mm diameters. For comparing the ANFIS, MLR and experimental results, determination coefficient ( $R^2$ ), root mean square error (RMSE) and standard error of estimates (SEE) statistics were used as evaluation criteria. It is concluded that ANFIS and MLR are practical methods for predicting the peak pressure load (PPL) values of the concrete pipes containing glass fibers and PPL values can be predicted using ANFIS and MLR without attempting any experiments in a quite short period of time with tiny error rates. Furthermore ANFIS model has the predicting potential better than MLR.

© 2011 Elsevier Ltd. All rights reserved.

### 1. Introduction

Concrete pipes are integral components of the community's infrastructure, being employed in a wide range of applications from storm-water drainage to external casing for composite piles (Fisher, Bullen, & Beal, 2001). Underground pipe systems have presented to improve human being standard of living since the dawn of civilization. Nowadays, underground pipe systems serve in various applications such as sewer lines, drain lines, water mains, gas lines, telephone and electrical conduits, culverts, oil lines, coal slurry lines, subway tunnels, and heat distribution lines (Moser, 2001). There are many types of piping materials in the construction sector today, ranging from rigid concrete to flexible thermal plastic. Pipes must have adequate strength and/or stiffness to perform their intended function. They must also be durable enough to last for their lifetime. Concrete pipes may be produced which conforms to the requirements of the respective specifications but with increased wall thickness and different concrete density. Concrete pipe products are made by several processes included nonreinforced products in sizes ranging from 4- to 36-in. diameter and various reinforced products in sizes 12- to 144-in. diameter (Moser, 2001, <http://www.concrete-pipe.org/pdf/cp-manual.pdf>). Concrete pipes have been in widespread usage area for water or sewage

conveyance in many areas like municipal, industrial, plant piping systems, etc. (Haktanir, Ari, Altun, & Karahan, 2007; Xiong, Li, & Li, 2010).

Glass fibers are type of high-strength fiber materials have many application areas in construction sector. Glass fibers commonly used composite materials in concrete owing to its great tensile strength and tensile module; glass fibers have great potential for use in concrete due to their superior characteristics in terms of high stiffness, low density and water absorption, high tensile strength, corrosion resistance etc. (Asokan, Osmani, & Price, 2009, 2010; Bai, Zhang, Yan, & Wang, 2009).

Designers utilize principles of science and mathematics to develop specific technologies. These technologies are then used to create engineered tools such as products, structures, machines, processes or entire systems. It has already been seen that different tasks in engineering problem solving require different analysis (Krishnamoorthy & Rajeev, 1996). Recently, artificial intelligence and statistical analysis have been extensively using in the fields of civil engineering applications such as construction management, building materials, hydraulic, geotechnical and transportation engineering etc. (Akkurt, Başıyigit, Kilincarslan, & Beycioğlu, 2010; Emiroğlu, Bilhan, & Kisi, 2010a, 2010b; Erdem, 2010; Kisi et al., 2009; Li, Huang, & Nie 2010; Mashrei, Abdulrazzaq, Turki, & Rahman, 2010; Moghaddamnia, Gousheh, Piri, Amin, & Han, 2009; Saltan & Terzi, 2008; Shiqiao, Haipeng, & Lei, 2009; Sobhani, Najimi, Pourkhorshidi, & Parhizkar, 2010; Subaşı, 2009; Słowski, 2010; Talei, Chua, & Wong, 2010; Terzi, 2007; Wu, Chau, & Fan, 2010; Yazar, Onucyıldız, & Copty, 2009; Yilmaz, Kok, Sengoz,

\* Corresponding author.

E-mail addresses: [mehmetemiroglu@duzce.edu.tr](mailto:mehmetemiroglu@duzce.edu.tr), [abeycioglu@duzce.edu.tr](mailto:abeycioglu@duzce.edu.tr) (A. Beycioğlu), [syildiz@firat.edu.tr](mailto:syildiz@firat.edu.tr) (S. Yildiz).

Sengur, & Avci, 2010; Yurdusev & Firat, 2009; Zarandi, Türksen, Sobhani, & Ramezaniyanpour, 2008).

One of the most popular artificial intelligence method is ANFIS. The acronym ANFIS derives its name from adaptive neuro-fuzzy inference system. ANFIS is the implementation of fuzzy inference system (FIS) to adaptive networks for developing fuzzy rules with

**Table 1**  
Properties of glass fiber.

Fiber length (µm)	Fiber diameter (µm)	Specific gravity	Young's modulus (GPa)	Tensile strength (GPa)	Strength at failure (%)
30–50	9–15	2.6	70–80	2.4	2–3.5

**Table 2**  
Chemical, physical and mechanical properties of the cement.

Chemical composition (%)	Physical properties
SiO <sub>2</sub>	20.42 Initial setting time, (h/m.) 02:25
Al <sub>2</sub> O <sub>3</sub>	5.92 Final setting time, (h/m.) 03:55
Fe <sub>2</sub> O <sub>3</sub>	2.81 Specific gravity 3.00
CaO	65.87 Specific surface (cm <sup>2</sup> /g) 3927
MgO	3.23 Mechanical properties (compressive strength (MPa))
SO <sub>3</sub>	0.97 7th day 27.5
Na <sub>2</sub> O + K <sub>2</sub> O	0.15 28th day 38.5
Loss on ignition	2.16
Unknown	0.18

**Table 3**  
Properties of the concrete specimens.

Glass fiber ratio (%)	Compressive strength (MPa)	Weight lost after 25 cycles of freeze–thawing (%)	Tensile strength (MPa)	Three point bending strength (MPa)
0.0	41.57	12.70	1.78	1.98
0.2	36.83	12.68	1.91	2.38
0.4	35.67	12.71	2.27	2.74
0.6	32.00	12.76	4.00	3.32

suitable membership functions to have required inputs and outputs. The neuro-adaptive learning method works similarly to that of neural networks. Neuro-adaptive learning techniques provide a method for the fuzzy modeling procedure to learn information about a data set. Fuzzy Logic Toolbox software computes the membership function parameters that best allow the associated fuzzy inference system to track the given input/output data. The Fuzzy Logic Toolbox function that accomplishes this membership function parameter adjustment is called ANFIS. The ANFIS function can be accessed either from the command line or through the ANFIS Editor GUI (Jang, 1993; <http://www.mathworks.cn/access/helpdesk/help/toolbox/fuzzy/fp715dup12.html#FP43142>).

In this study, the effects of glass fiber content on peak pressure load of concrete pipes were investigated by using ANFIS Editor GUI and statistical approach. For this purpose, concrete pipes having varying diameters were prepared with using 0, 0.2, 0.4 and 0.6% glass fiber by weight. Prediction of peak pressure load of concrete pipes produced with varying amount of glass fiber was determined as statistical and ANFIS approximation.

**2. Material and method**

The experimental program was designed to examine the peak pressure load of concrete pipes. The materials used to develop the concrete mixes in the study were aggregate, cement, water and short glass fibers. The aggregate having 31.5 mm maximum aggregate diameter and 2.70 g/cm<sup>3</sup> specific gravity were obtained from Elazığ/Çemişgezek region. CEM I 32,5 R was used in all mixes. The properties of glass fibers and cement used in this study are listed in Tables 1 and 2 respectively.

A plain concrete mix was designed as a control (without glass fiber) mix. The mix required 0.39 water-cement ratio. In the rates of 0.2, 0.4 and 0.6% by weight glass fibers were supplemented to the concrete mix for preparing the glass fiber reinforced concrete specimens. Because of water absorption capacity of glass fiber water-cement ratio was increased depending on glass fiber content, thus water-cement ratio was ranged from 0.39–0.48. Prepared concrete mixes were moulded and cured during 28 days for determining the compressive strength. 28th day compressive

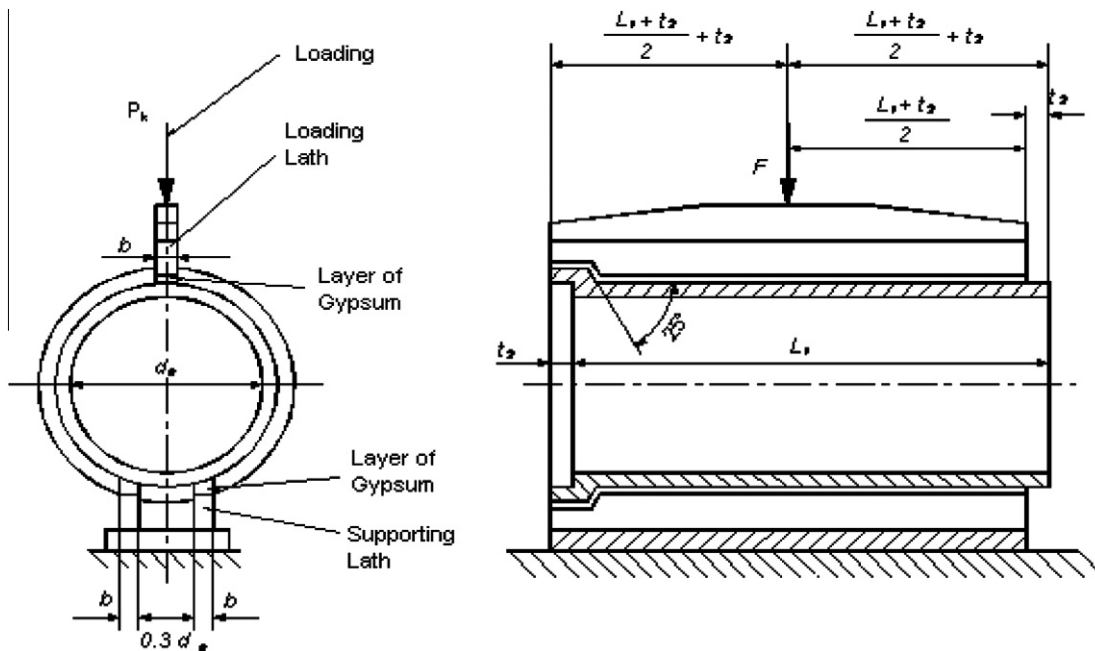

**Fig. 1.** Peak load pressure test setup.

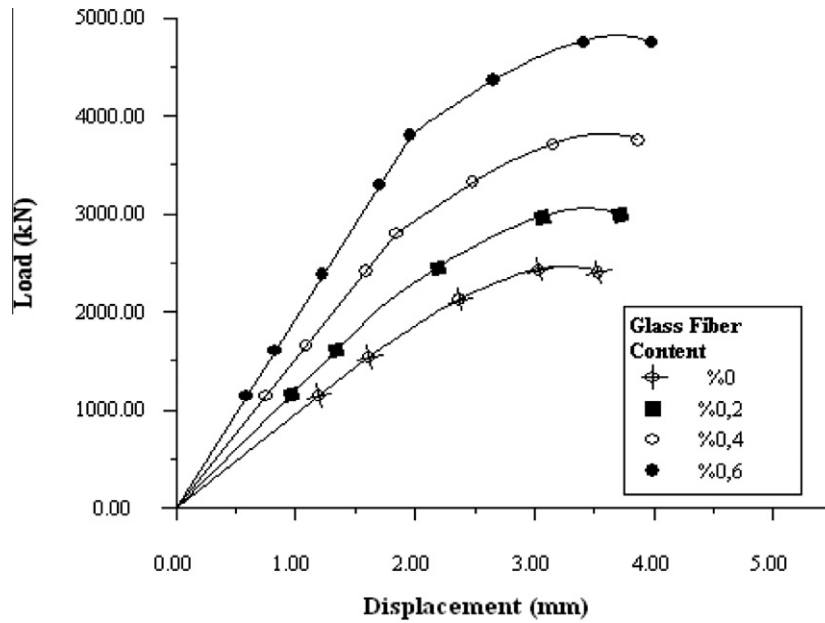

Fig. 2. Load-displacement graphics of the specimens.

Table 4  
Descriptive statistics.

Inputs	N	Range	Minimum	Maximum	Mean	Std. deviation	Variance
Pipe diameter (cm)	20	40.00	20.00	60.00	40.0000	14.50953	210.526
Glass fiber content (%)	20	0.60	0.00	0.60	0.3000	0.22942	0.053
Peak pressure load (kN/m)	20	63.48	32.17	95.65	57.9345	18.72793	350.735

Table 5  
Model summary.

Model	R	R square	Adjusted R square	Std. error of the estimate	Change statistics		
					R square change	F change	Sig. F change
1	0.981	0.962	0.960	3.60166	0.962	520.257	0.000

Predictors: (constant), glass fiber, pipe diameter – dependent variable: peak pressure load.

strength, tensile strength, bending strength and freeze thaw degradation of concrete mixes is listed in Table 3.

Five different diameters (20, 30, 40, 50, and 60 cm) were selected for preparing the concrete pipes. On the all the concrete pipe specimens the peak pressure load test were performed at the 28th day of the casting. Peak pressure load test is carried out on the full length of the concrete pipes. Test specimen is immersed to the water during 24 h before the test in order to obtain saturated surface. The experimental test setup for peak pressure load of concrete pipe is demonstrated in Fig. 1 (TS-821-EN-1916, 2005).

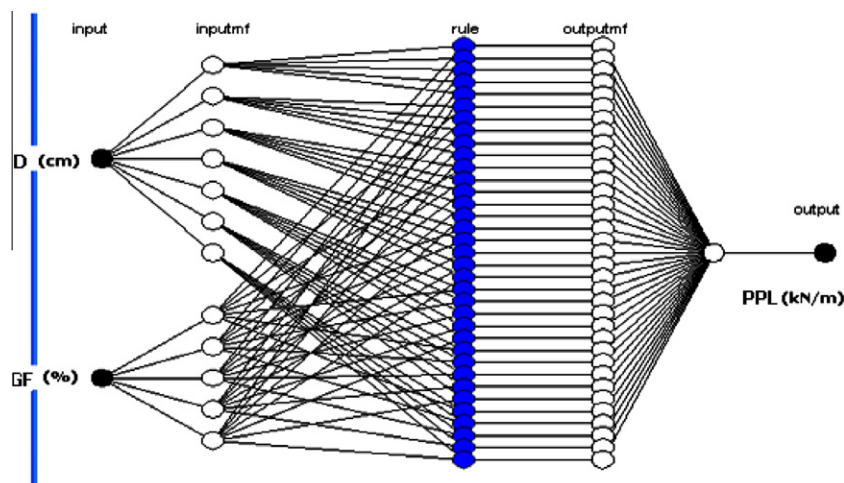

Fig. 3. General structure of the model.

It is observed that increasing the concrete pipe diameter and glass fiber content peak pressure load results were increased. Peak pressure load test values are varying from 32,17 and 95,65 kN/m. It is clear from Fig. 2 that, use of glass fiber in concrete, deformation capacity of the concrete pipes is increased. After the experimental test, also both statistical and ANFIS approximations were conducted for the prediction of peak pressure load values of concrete pipes.

### 3. Statistical analysis

For the determining regression equation pipe diameter ( $D$ ) and glass fiber ( $GF$ ) content were selected as independent and peak pressure load values were selected as dependent variables. Descriptive statistics of peak pressure load values, pipe diameter and glass fiber content were determined using SPSS statistical program and listed in Table 4 (Kalaycı, 2008).

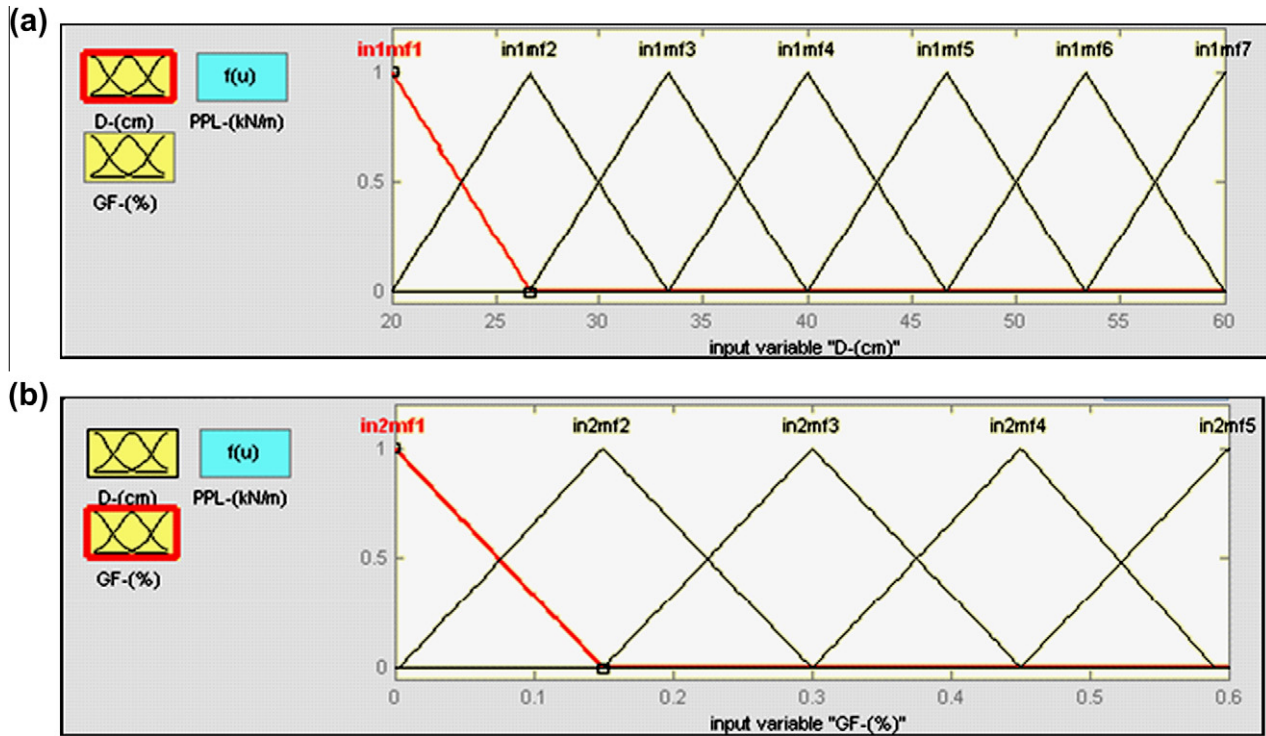

Fig. 4. (a),(b). Membership functions of inputs.

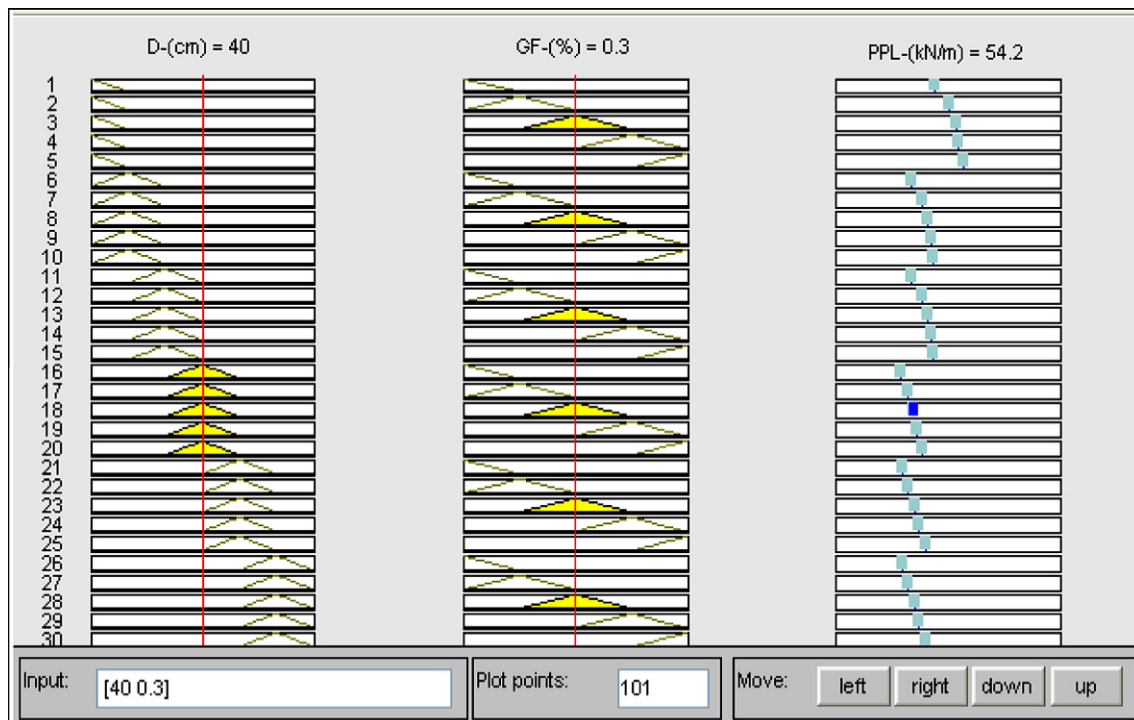

Fig. 5. Defuzzification monitor of the model.

A Multiple Linear Regression (MLR) analysis was performed and an empirical correlation predicting peak pressure load was developed for concrete pipes. In the model 44 of the 60 experimental data selected for training the MLR analysis and 16 experimental data used for comparison of the experimental and statistical results. The resulting correlation at training stage is given in Eq. (1) and the regression model summary is listed in Table 5.

$$PPL = 3,060 + 1,229D + 18,997GF. \tag{1}$$

Where; PPL is peak pressure load (kN/m), *D* is pipe diameter (cm) and *GF* is glass fiber content (%).

16 experimental peak pressure load values were compared with the predicted values obtained from Eq. (1). Good agreement between experimental peak pressure load and the values computed from the predictive equation was obtained.

#### 4. Developed ANFIS model

ANFIS model developed in this research has two inputs that pipe diameters (*D*) and glass fiber ratio (by weight – *GF*) and an output overload strength of the concrete pipes (PPL) as illustrated in Fig. 3. While developing the model 44 experimental data used for training and 16 experimental data used for testing. After experimenting different learning algorithms with different epochs, best correlations was found through hybrid learning algorithm and 1000 epochs. In the model 7 “trimf” membership functions were selected for pipe diameters (*D*) and 5 “trimf” membership functions were selected for glass fiber ratio (by weight – *GF*). The numerical range were used for *D* (20–60), for *GF* (0–0.6), respectively. Membership functions of inputs are displayed in Fig. 4(a) and (b). Also the membership functions are detailed as below

```
Name = 'D'
Range = [20 60]
NumMFs = 7
MF1 = 'inlmf1' : 'trimf', [13.33333333333333 20
26.66666666666667]
MF2 = 'inlmf2' : 'trimf', [20.0000012497276
26.66666666666669 33.33333333333336]
MF3 = 'inlmf3' : 'trimf', [26.66666666666669
33.33333333333336 39.999988138361]
MF4 = 'inlmf4' : 'trimf', [33.33333333333333 40
46.66666666666667]
MF5 = 'inlmf5' : 'trimf', [40 46.66666666666475
53.3333333333142]
MF6 = 'inlmf6' : 'trimf', [46.66666666666475
53.3333333333142 59.9999803658003]
MF7 = 'inlmf7' : 'trimf', [53.33333333333333 60
66.6666666666667]

Name = 'GF'
Range = [0 0.6]
NumMFs = 5
MF1 = 'in2mf1' : 'trimf', [-0.15 -1.70231419269074e-
013 0.15]
MF2 = 'in2mf2' : 'trimf', [0.00309143120554203
0.149850468359392 0.299925234179697]
MF3 = 'in2mf3' : 'trimf', [0.149700936719579
0.30039218984099 0.4510834429624]
MF4 = 'in2mf4' : 'trimf', [0.300270860740787
0.450541721481583 0.590585614856746]
MF5 = 'in2mf5' : 'trimf', [0.45 0.600000000000057
0.75]
```

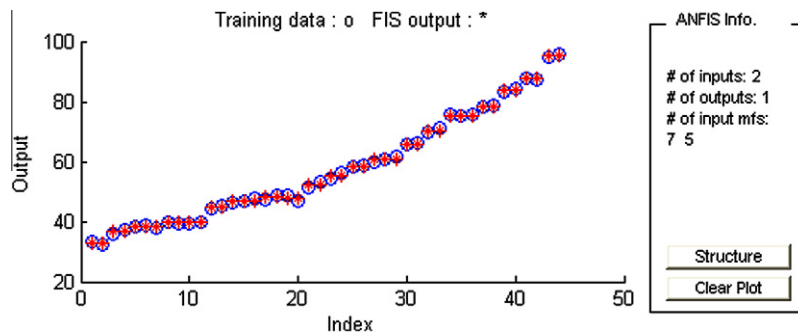

Fig. 6. Matching figure of results for training (ANFIS-exp).

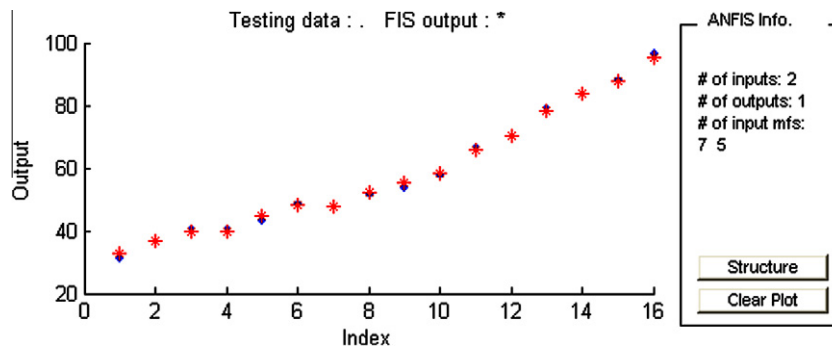

Fig. 7. Matching figure of results for testing (ANFIS-exp).

In the model 35 rules define the relationship between inputs and output. After training, the model was tested only using test input data by defuzzification monitor. The models defuzzification monitor is shown in Fig. 5. Also Figs. 6 and 7 shows matching figure of the measured results with the results obtained from developed ANFIS model for training and testing stage.

**5. Results and discussion**

The adequacy of the developed ANFIS and MLR models were evaluated by considering the coefficient of determination ( $R^2$ ) Eq. (2), root mean squared error (RMSE) Eq. (3) and Standard Error of the Estimate (SEE) Eq. (4).

**Table 6**  
Statistics of peak pressure load estimation using ANFIS and MLR.

		Statistics			
		R-square	Adjusted R-square	SEE	RMSE
Training stage	MLR	0.9621	0.9612	531.8	3.559
	ANFIS	0.9989	0.9989	15.47	0.6069
Testing stage	MLR	0.9562	0.9531	260.5	4.314
	ANFIS	0.9981	0.9980	11.15	0.8923

$$R^2 = 1 - \left\{ \frac{\left[ \sum_{i=1}^n (Y_{i(observable)} - Y_{i(model)})^2 \right]}{\left[ \sum_{i=1}^n (Y_{i(observable)} - Y_{i(mean)})^2 \right]} \right\} \quad (2)$$

$$RMSE = \sqrt{\frac{1}{N} \sum_{i=1}^N (Y_{i(observable)} - Y_{i(predicted)})^2} \quad (3)$$

$$SEE = \sum_{i=1}^n (Y_{i(observable)} - Y_{i(model)})^2 \quad (4)$$

The relationship between the input and output variables are established using two models, an ANFIS and a Multiple Linear Regression (MLR) models.

The results derived from Table 6 showed that the proposed ANFIS model for predicting peak pressure load has highly predictive capability rather than MLR model. The ANFIS model also pointed out better performance than regression model. Fig. 8(a),(b),(c) and (d) show the model performances of the ANFIS and MLR modeling based on the 95% prediction bounds illustrated on the figures and linear curve fitting statistics summarized in Table 6.

According to the comparison of the curve fitting statistics, ANFIS results perform better than the MLR both training and the testing stage for glass fiber reinforced concrete pipes. As can be seen from Table 6 and Fig. 8 (a–d), the smallest prediction errors are observed in ANFIS model according to the curve fitting statistics. The RMSE values of the MLR and ANFIS model at the training

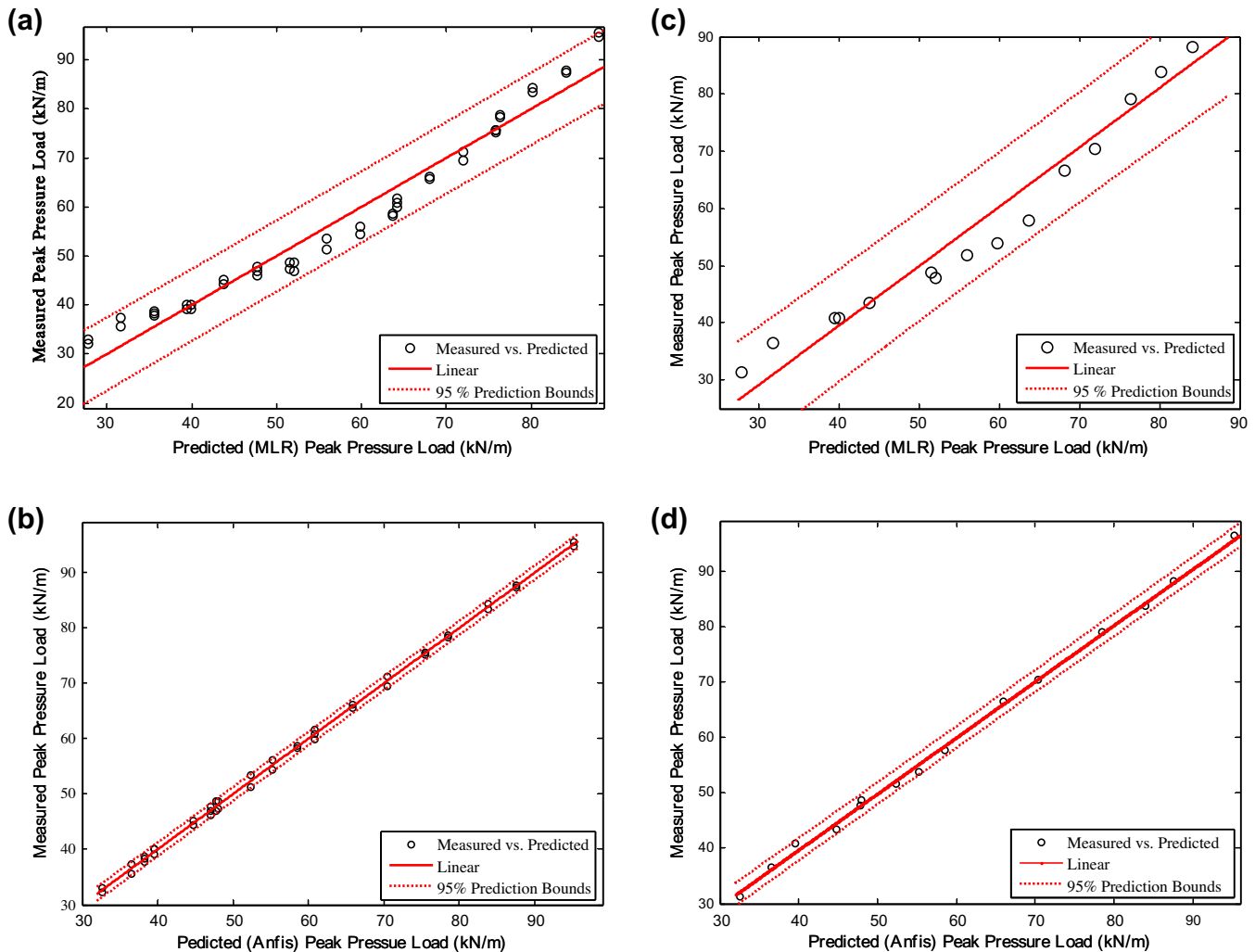

**Fig. 8.** Comparison of experimental peak pressure load values with the predicted values calculated from Eq. (1). (a) Training stage of MLR, (b) training stage of ANFIS, (c) testing stage of MLR and (d) testing stage of ANFIS.

stage are 3.559 and 0.6069 respectively. Besides, the RMSE values of the MLR and ANFIS model at the testing stage are 4.314 and 0.8923 respectively. All of the statistical values in Table 6 show that the ANFIS model is suitable and predicted the peak pressure load values very close to the experimental values than MLR.

## 6. Conclusions

The potential of the ANFIS model for estimation of the peak pressure load values of the concrete pipes containing glass fibers has been investigated and compared with the well known statistical method multi linear regression technique in this research. While developing the two models, 44 experimental data (randomly selected) used for training and 16 experimental data (the residual data) used for testing the models. While Developing ANFIS model, different learning algorithms with different epochs were experimented to define the model which has best potential estimation ability to predict experimental results. A best correlation was found through hybrid learning algorithm and 1000 epochs. After finding the best ANFIS model, results of ANFIS, MLR and experimental results were compared. For comparing the ANFIS, MLR and experimental results, determination coefficient ( $R^2$ ), root mean square error (RMSE) and standard error of estimates (SEE) statistics were used as evaluation criteria. When comparing the prediction and the experimental values in the training stage RMSE –  $R^2$  and SEE were found as 3.559, 0.9621 and 531.8 for MLR model 0.6069, 0.9989, 15.47 for ANFIS model respectively. Similarly comparisons were done at the test stage and RMSE –  $R^2$  and SEE were found as 4.314, 0.9562 and 260.5 for MLR model 0.8923, 0.9981 and 11.15 for ANFIS model respectively. The values obtained from both ANFIS and MLR models were close to the experimental results. As a result, the peak pressure load values of the concrete pipes containing glass fibers can be predicted in the models in ANFIS and MLR without attempting any experiments in a quite short period of time with tiny error rates. Conclusions have shown that ANFIS and MLR are practical methods for predicting the peak pressure load values of the concrete pipes containing glass fibers. Furthermore ANFIS model has the predicting potential better than MLR.

## References

- Akkurt, I., Basyigit, C., Kilincarslan, S., & Beycioglu, A. (2010). Prediction of photon attenuation coefficients of heavy concrete by fuzzy logic. *Journal of the Franklin Institute*, 347(9), 1589–1597.
- Asokan, P., Osmani, M., & Price, A. D. F. (2009). Assessing the recycling potential of glass fiber reinforced plastic waste in concrete and cement composites. *Journal of Cleaner Production*, 17, 821–829.
- Asokan, P., Osmani, M., & Price, A. D. F. (2010). Improvement of the mechanical properties of glass fibre reinforced plastic waste powder filled concrete. *Construction and Building Materials*, 24, 448–460.
- Bai, W., Zhang, J., Yan, P., & Wang, X. (2009). Study on vibration alleviating properties of glass fiber reinforced polymer concrete through orthogonal tests. *Materials and Design*, 30, 1417–1421.
- Emiroglu, M. E., Bilhan, O., & Kisi, O. (2010a). Neural networks for estimation of discharge capacity of triangular labyrinth side-weir located on a straight channel. *Expert System with Application*, 38(1), 2011.
- Emiroglu, M. E., Bilhan, O., & Kisi, O. (2010b). Predicting discharge capacity of triangular labyrinth side weir located on a straight channel by using an adaptive neuro-fuzzy technique. *Advances in Engineering Software*, 41(2), 154–160.
- Erdem, H. (2010). Prediction of the moment capacity of reinforced concrete slabs in fire using artificial neural networks. *Advances in Engineering Software*, 41(2), 270–276.
- Fisher, A. K., Bullen, F., & Beal, D. (2001). The durability of cellulose fiber reinforced concrete pipes in sewage applications. *Cement and Concrete Research*, 31(4), 543–553.
- Haktanir, T., Ari, K., Altun, F., & Karahan, O. (2007). A comparative experimental investigation of concrete. *Construction and Building Materials*, 21, 1702–1708.
- Jang, J. S. R. (1993). ANFIS: Adaptive network based fuzzy inference system. *IEEE Transactions on Fuzzy Systems, Man and Cybernetics*, 23, 665–685.
- Kalaycı, Ş. (2008). SPSS Uygulamalı Çok Değişkenli İstatistik Teknikleri. Asil Yayın Dağıtım Ltd. Şti, (3rd. ed.). Ankara 2008 (in Turkish).
- Kisi, O., Haktanir, T., Ardiclioglu, M., Ozturk, O., Yalcin, E., & Uludag, S. (2009). Adaptive neuro-fuzzy computing technique for suspended sediment estimation. *Advances in Engineering Software*, 40(6), 438–444.
- Krishnamoorthy, C. S., & Rajeev, S. (1996). *Artificial intelligence and expert systems for engineers*. CRC Press.
- Li, Y. P., Huang, G. H., & Nie, S. L. (2010). Planning water resources management systems using a fuzzy-boundary interval-stochastic programming method. *Advances in Water Resources*, 33(9), 1105–1117.
- Mashrei, M. A., Abdulrazzaq, N., Turki, Y. A., & Rahman, M. S. (2010). Neural networks model and adaptive neuro-fuzzy inference system for predicting the moment capacity of ferrocement members. *Engineering Structures*, 32(6), 1723–1734.
- Moghaddamnia, A., Gousheh, G. M., Piri, J., Amin, S., & Han, D. (2009). Evaporation estimation using artificial neural networks and adaptive neuro-fuzzy inference system techniques. *Advances in Water Resources*, 32(1), 88–97.
- Moser, A. P. (2001). *Buried pipe design* (2nd ed.). New York: McGraw-Hill.
- Saltan, M., & Terzi, S. (2008). Modeling deflection basin using artificial neural networks with cross-validation technique in backcalculating flexible pavement layer moduli. *Advances in Engineering Software*, 39(7), 588–592.
- Shiqiao, G., Haipeng, L., & Lei, J. (2009). A fuzzy model of the penetration resistance of concrete targets. *International Journal of Impact Engineering*, 36(4), 644–649.
- Słoński, M. (2010). A comparison of model selection methods for compressive strength prediction of high-performance concrete using neural networks. *Computers & Structures*, 88(21–22), 1248–1253.
- Sobhani, J., Najimi, M., Pourkhorshidi, A. R., & Parhizkar, T. (2010). Prediction of the compressive strength of no-slump concrete: A comparative study of regression, neural network and ANFIS models. *Construction and Building Materials*, 24(5), 709–718.
- Subaşı, S. (2009). Prediction of mechanical properties of cement containing class C fly ash by using artificial neural network and regression technique. *Scientific Research and Essays*, 4(4), 289–297.
- Talei, A., Chua, L. H. C., & Wong, T. S. W. (2010). Evaluation of rainfall and discharge inputs used by adaptive network-based fuzzy inference systems (ANFIS) in rainfall–runoff modeling. *Journal of Hydrology*, 391(3–4), 248–262.
- Terzi, S. (2007). Modeling the pavement serviceability ratio of flexible highway pavements by artificial neural networks. *Construction & Building Materials*, 21, 590–593.
- TS-821-EN-1916. (2005). Concrete pipes and fittings, unreinforced, steel fibre and reinforced. Turkish Standards Institute, Ankara: Turkey.
- Wu, C. L., Chau, K. W., & Fan, C. (2010). Prediction of rainfall time series using modular artificial neural networks coupled with data-preprocessing techniques. *Journal of Hydrology*, 389(1–2), 146–167.
- Xiong, H., Li, P., & Li, Q. (2010). FE model for simulating wire-wrapping during prestressing of an embedded prestressed concrete cylinder pipe. *Simulation Modelling Practice and Theory*, 18, 624–636.
- Yarar, A., Onucyıldız, M., & Coptay, N. K. (2009). Modelling level change in lakes using neuro-fuzzy and artificial neural networks. *Journal of Hydrology*, 365(3–4), 329–334.
- Yilmaz, M., Kok, B. V., Sengoz, B., Sengur, A., Avci, E. (in press). Investigation of complex modulus of base and EVA modified bitumen with Adaptive-Network-Based Fuzzy Inference System. *Expert Systems with Applications*, 10.1016/j.eswa.2010.07.088.
- Yurdusev, M., & Firat, A. M. (2009). Adaptive neuro fuzzy inference system approach for municipal water consumption modeling: An application to Izmir, Turkey. *Journal of Hydrology*, 365(3–4), 225–234.
- Zarandi, M. H. F., Türksen, I. B., Sobhani, J., & Ramezani-pour, A. A. (2008). Fuzzy polynomial neural networks for approximation of the compressive strength of concrete. *Applied Soft Computing*, 8(1), 488–498.